



Fleetwood Slideout Systems Operations Manual

©PowerGear 10/05 #82-S0010-01 Rev. OC

Contents

Introduction	1
System Description	1
Operating the Slideout System	2
Overriding the Slideout System	2
Troubleshooting (Electric Wiring)	3
Preventative Maintenance	4

Fleetwood Motorhome Slideout Systems Operations Manual

Introduction

The Power Gear electric slide out system in your unit is designed to give you years of trouble-free operation and reflects the latest state of the art technology. Read, study, and understand this manual before operating this Slideout System.



System Description

The Power Gear Slideout System consists of four major components:

- Two inner rail assemblies (one for bedroom or wardrobe) designed to support the room weight.
- A 12 volt DC motor and drive shaft that will operate the room using power from the on-board unit battery.
- A Manual Override System that allows you to extend / retract the room in the event of loss of power.
- A specially designed control that gives the user full control of the room movement in or out. The control has a load sensing capability that stops the motor when the room reaches its fully extended or retracted positions.



WARNING

- » Always make sure that the unit is level before operating the Slideout room.
- » Always make sure there are no obstructions blocking the path of the room when it is moving.
- » Always make sure that the room path is clear of people and objects before operating.
- » Always keep away from the slide rails when the room is in motion. The gear assembly may pinch or catch on loose clothing causing person injury.
- » Failure to follow these instructions could result in serious injury or death.

Operating the Slideout System

Before you operate the Power Gear Slideout System, make sure:

1. The path is clear for the room to move.
2. The battery is fully charged and hooked up to the unit's electrical system.
3. The unit is level.

Extending the Room

1. Insert the Switch Key into the Slideout Room Control.
2. Turn the Switch Key to the OUT position.
3. Hold the Switch in the OUT position until the room is fully extended and stops moving. The control will sense that the room has stopped and will automatically shut off the motor, locking the room into place.
4. Release the Switch Key.
5. The Key may now be removed from the Switch if necessary.

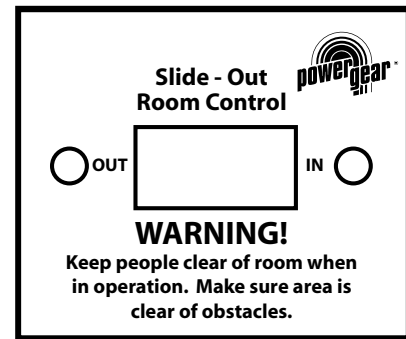

Retracting the Room

1. Insert the Switch Key into the Slideout Room Control
2. Turn the Switch Key to the IN position.
3. Hold the Switch in the IN position until the room is fully retracted and stops moving. The Control will sense that the room has stopped and will automatically shut off the motor, locking the room into place.
4. Release the Switch Key.
5. The Key may now be removed from the Switch if necessary.

Overriding the Slideout System

Your Power Gear Slideout System is equipped with a manual override that allows you to extend or retract a room in the event of a loss of power.

If your system will not move when the Switch is pressed, make sure that the system is turned on and the battery is connected and has a full charge. After all of these are completed, follow these simple steps to move the room manually.

Main Room Slideout

1. Make sure that the ON/OFF Switch Key for the system is turned off.
2. Locate the Slideout Motor. It will be either ahead of the front rail or behind the back rail.
3. Locate the two-pin connector on the

Slideout Motor leads and disconnect.

4. Rotate the lever on the backside of the motor counter-clockwise about 1/8th turn (looking from the rear of the motor). This will release the break that holds the room in place.
5. The room is now free to move. Using a 3/4th wrench or ratchet, crank the room either in or out (depending on your need) using the manual override.
6. When the room is fully in or out, have one person put pressure on the wrench/ratchet to ensure a tight seal while the another person returns the Brake Lever to its normal downward locked travel position. This will ensure that the room is locked into a sealed position.
7. Take the unit to an authorized dealer for service.

! WARNING

» When the Slideout room Motor Brake Lever is released, the room will not lock into place and therefore not be sealed from the outside elements.

» When the room has been cranked in, be sure to return the Motor Brake Lever to its normal downward position in order to seal and lock the room.

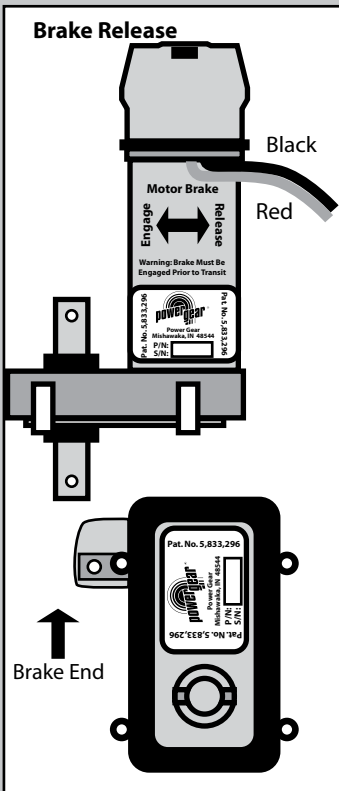
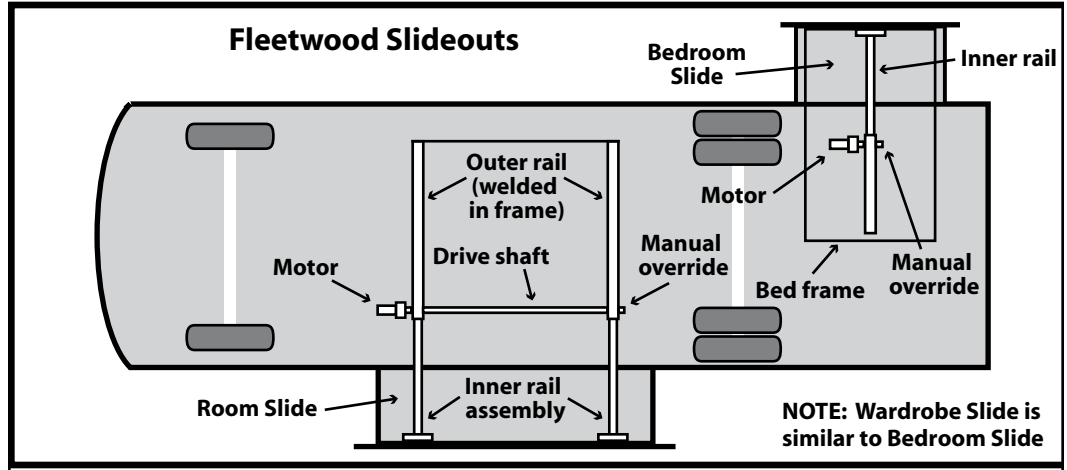

Bedroom / Wardrobe Slideout

1. Make sure that the ON/OFF Switch Key for the system is turned off.
2. Locate the Slideout mechanism. To access the bedroom Slideout, lift up the mattress and baseboard. To access the wardrobe Slideout, open the outside luggage compartment below the wardrobe.
3. Locate the two-pin connector on the Slideout Motor leads and disconnect.
4. The bedroom Slideout Motor has a lever on the backside. Rotate the lever counter-clockwise about 1/8th turn (looking from the rear of the motor). This will release the break that holds the room in place.
5. The room is now free to move. Using a 3/4th wrench/ratchet or adjustable wrench, crank the room either in or out (depending on your need) using the manual override. The manual override is located on the opposite side of the Slideout rail from the Motor.
6. When the room is fully in or out, put pressure on the wrench/ratchet to ensure a tight seal and return the Brake Lever to its normal downward locked travel position. This will ensure that the room is locked into a sealed position.
7. Take the unit to an authorized dealer for service.

Troubleshooting

Electrical Wiring Information

The wiring for the Slideout should be completed per the following diagram. The switch wires, motor wires and ground wire can be connected to the control at any time during installation prior to the power being connected. The battery line must be connected BEFORE the battery is connected.

» **NOTE:** If the motor runs in the reverse direction, switch motor leads.

! CAUTION

» The Control Box WILL be damaged if any of the leads are grounded or touched together when power is connected to the system.

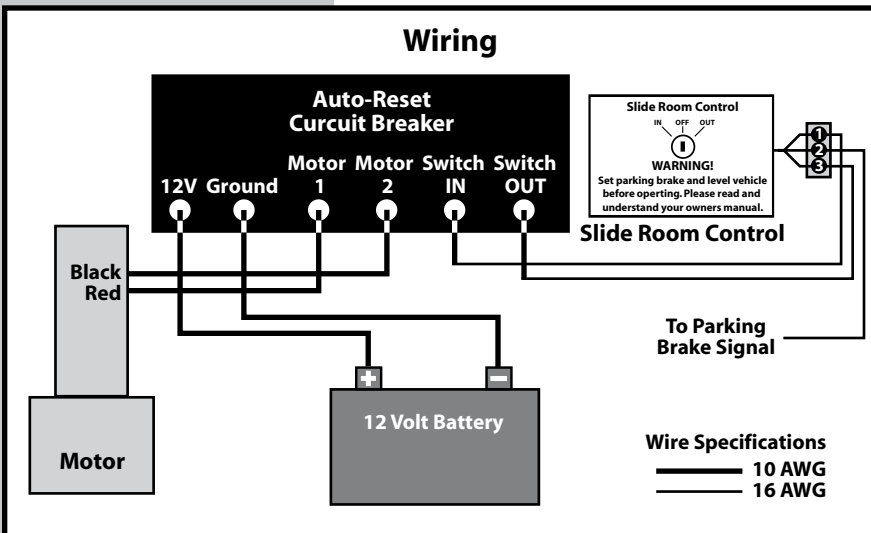

CAUTION

» Do not work on your system unless the battery is disconnected.

Preventative Maintenance

Your Power Gear Slideout system has been designed to require very little maintenance. To ensure the long life of your Slideout system, read and follow these few simple procedures:

- When the room is out, visually inspect the inner slide rail assemblies. Check for excess buildup of dirt or foreign material. Remove any debris that may be present.
- If the system squeaks or makes any noises, it is permissible to apply a coat of light weight oil to the drive shaft and roller areas. Remove any excess oil so dirt and debris do not build up.

If you have any problems or questions consult your local authorized dealer or call us at Power Gear, 1-800-334-4712.

