



SERVICE INSTRUCTIONS FOR SEAL REPLACEMENT OF POWER GEAR HYDRAULIC LEVELING LEGS

POWER GEAR BASE LEG PART NUMBER SEAL REPAIR KIT PART NUMBERS:

Jack assembly #'s	Cap. (lbs.)	Application	Kit #
500384,500384H,500384HR, 500482H	6000	2001-present	800132S
500082,500082H,500082HR,500146,500235H,500272	9000	2003 & prior	800129S
500385TH	12,000	2003 & prior	800137S
500070,500070TH,500145	16,000	2003 & prior	800131S
500386T,500620	24,000	2003 & prior	800130S
Power Level Jacks	Cap. (lbs.)	Application	Kit #
500876,500730,500832,500842,500933	6000	Power Level	800133S
500759,500833,500843,500932	9000	Power Level	800138S
500800	12,000	Power Level	800199S

82-L0352

REV 7

WARNING!

HYDRAULIC COMPONENTS CAN CAUSE SERIOUS INJURY OR DEATH IF PROPER SAFETY PRECAUTIONS ARE NOT FOLLOWED. ALL HYDRAULIC PRESSURE MUST BE RELEASED FROM THE SYSTEM, INCLUDING RAISING ALL JACKS AND REMOVING POWER FROM THE SYSTEM BEFORE REMOVAL OR DISASSEMBLY IS ATTEMPTED.

ALWAYS WEAR SAFETY EQUIPMENT. SAFETY GLASSES, GOGGLES AND/OR FACE SHIELDS CAN PREVENT SERIOUS INJURY AND SHOULD BE USED TO PREVENT EYE DAMAGE.

POWER GEAR WARRANTS THE SEALS AND COMPONENTS OF THESE KITS FOR 90 DAYS AGAINST DEFECTS IN MATERIALS AND WORKMANSHIP. NO GUARANTEE EXISTS ON THE ULTIMATE SUCCESS OR FAILURE OF THE JACK. THE SUCCESS OF THE RESEAL DEPENDS ON THE CARE TAKEN DURING INSPECTION, THE SKILL OF THE TECHNICIAN AND THE CLEANLINESS DURING THE RE-ASSEMBLY. ANY DEFECT ON THE SURFACE OF THE ROD WILL RESULT IN SEAL FAILURE OR REDUCE THE LIFE OF THE SEALS.

NOT ALL JACKS CAN BE DISASSEMBLED DUE TO VARIANCES IN ASSEMBLY TECHNIQUE, DISASSEMBLY TOOLS AVAILABLE OR DAMAGE DUE TO ENVIRONMENTAL CONDITIONS OR ABUSE. WHILE ONLY A VERY SMALL PERCENTAGE OF JACKS ARE IMPOSSIBLE TO DISASSEMBLE, JACKS SHOULD BE DISASSEMBLED BEFORE SEAL REPLACEMENT OR JACK REPLACEMENT COSTS ARE DETERMINED.

TABLE OF CONTENTS

<u>LEG IDENTIFICATION INFORMATION</u>	<u>PAGE 4</u>
<u>TOOL REQUIREMENTS</u>	<u>PAGE 5</u>
<u>INTERNAL SPRING LEGS</u>	<u>PAGE 6</u>
<u>EXTERNAL SPRING LEGS</u>	<u>PAGE 14</u>
<u>POWER LEVEL LEGS</u>	<u>PAGE 21</u>

TOOL REQUIREMENTS:

NOTE: Some tools may not be required for some jacks. This is a complete tool list to equip a technician for repairs to all types of Power Gear leveling cylinders.

- 1/4" punch
- 1/8" punch
- hammer
- strap wrench
- Small pick or screwdriver
- Grease gun
- Large spanner wrench
- Bench vise
- 15/16" socket
- 9/16" socket
- 7 mm socket
- Impact wrench
- Torque wrench
- Clean lint free shop towels
- Loctite® 243 or equivalent
- Wire brush
- Spray cleaning solvent
- Compressor
- Large pipe wrench or chain wrench
- Small propane torch

Hydraulic LEG IDENTIFICATION INFORMATION

Leveling Jack #	Jack obsolete use #	Rebuild kit #	Dimensions	Spring #
500385TH 12K	500385TH	Kit # 800137S	A=22.25 B=3.625 C=20.11	500094
500070TH 16K	500070TH	Kit # 800137S	A=22.3 B=3.63 C=20.11	500094
500070TH 16K		Kit # 800131S	A=22.25 B=4.0 C=21.42	500094
501137 16K		Kit# 800131S	A=22.37 B=4.0 C=18.94	500094
500386T 24K		Kit # 800130S	A=22.375 B=4.5 C=20.09	500094
500386T 24K		Kit # 800130S	A=22.375 B=4.5 C=20.09	500094
500620 24K	has mounting pad width of 7.25	Kit # 800130S	A=22.375 B=4.5 C=22.37	500094

internal springs not available



Internal Spring

Leveling Jack #	Jack obsolete use #	Rebuild kit #	Dimensions	Spring #
500082H 9K	500146	800129S	A=20.75 B=3.25 C=17.38	500094
500082H 9K		800129S	A=20.75 B=3.25 C=17.38	500094
500146 9K		800129S	A=20.75 B=3.25 C=17.38	500094
500272 9K	obsolete	800129S	A=20.75 B=3.25 C=17.82	500094
500235H 9K		800129S	A=18.25 B=3.25 C=17.38	500252
500498 9K		800129S	A=17.75 B=3.25 C=15.0	500252
500498H 9K		800129S	A=17.75 B=3.25 C=15.0	500252
500384H 6K	501022	800132S	A=21.25 B=2.625 C=17.61	500590
500384HR 6K		800132S	A=21.25 B=2.625 C=17.61	500590
500598 6K	500384HR	800132S	A=21.25 B=2.625 C=18.17	500590
500482 6K	500482H	800132S	A=18.0 B=2.625 C=15.38	500591
500482H 6K		800132S	A=18.0 B=2.625 C=15.38	500591
500600 6K	flat pad 500482H	800132S	A=18.0 B=2.625 C=15.63	500591
500800 12K		Kit# 800199S	A=19.2 B=3.25 C=16.75	500094
500759 9K		Kit# 800139S	A=20.85 B=2.6 C=17.6	500094
501315 12K		Kit# 800199S	A=20.33 B=3.25 C=17.19	500094

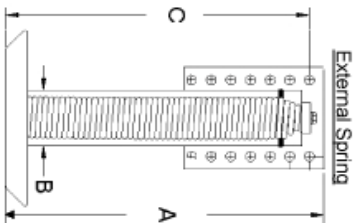

External Spring

Leveling Jack #	Jack obsolete use #	Rebuild kit #	Dimensions	Spring #
500730 6K		Kit# 800133S	A=19.15 B=2.25 C=16.0 D=8.0 E=1.125	500591
500832 6K		Kit# 800133S	A=23.25 B=2.25 C=22.3 D=8.0 E=5.0	500591
500842 6K		Kit# 800133S	A=20.4 B=2.25 C=19.5 D=14.3 E=2.5	500591
500876 6K		Kit# 800133S	A=18.94 B=2.25 C=17.0 D=12.3 E=.5	500591
500933 6K		Kit# 800133S	A=19.75 B=2.25 C=17.75 D=12.3 E=1.5	500591
500833 9K		Kit# 800139S	A=23.15 B=2.6 C=22.2 D=14.3 E=3.0	500094
500843 9K		Kit# 800139S	A=21.15 B=2.6 C=20.2 D=14.3 E=1.0	500094
500932 9K		Kit# 800139S	A=25.3 B=2.6 C=24.4 D=14.3 E=5.0	500094
501004 9K		Kit# 800139S	A=24.25 B=2.625 C=23.25 D=16.0 E=3.4	500094
501005 12K		Kit# 800199S	A=24.26 B=3.25 C=23.26 D=16.0 E=5.0	500094
3510000111 12K		Kit# 800199S	A=20.21 B=19.27 C=20.26 D=14.31 E=1.5	500094

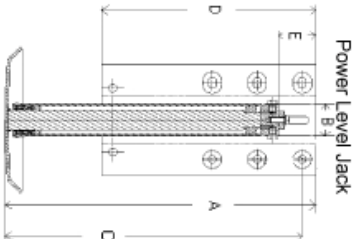

Power Level Jack

Spring Kit #	measurement of spring
500094	2.5" X 17"
500252	2.5" X 14.55"
500590	2.3" X 17"
500591	2.3" X 14.55"

INTERNAL SPRING LEGS

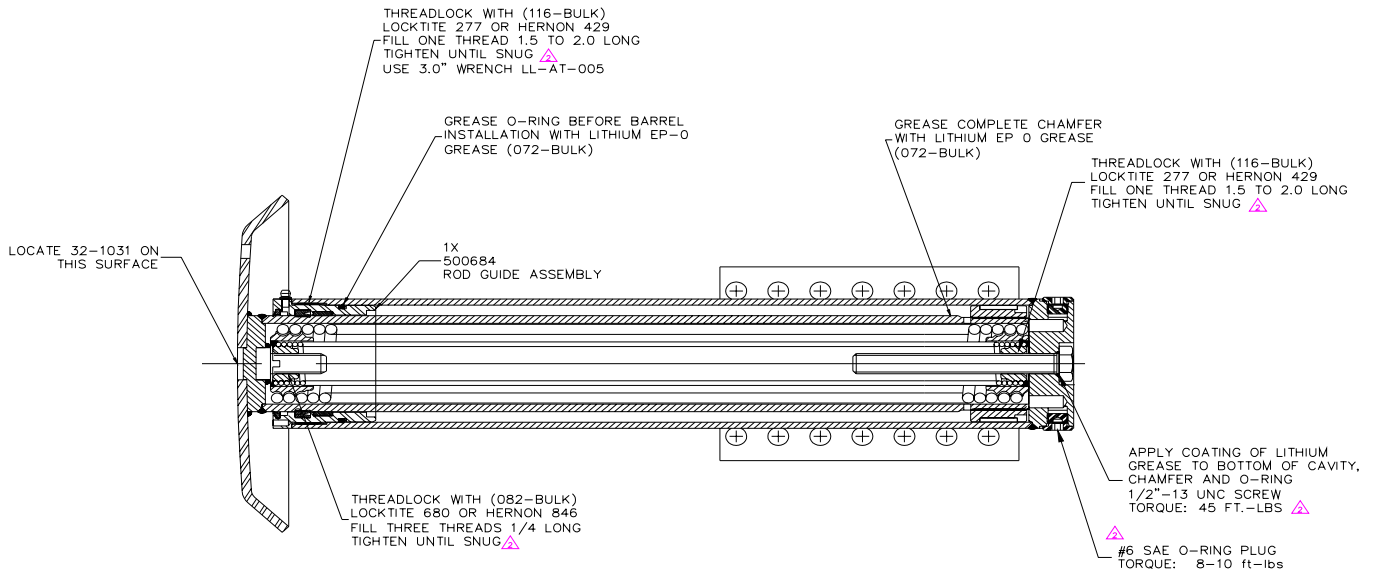

**EXAMPLE OF A TYPICAL
POWER GEAR HYDRAULIC LEG CROSS SECTION
LEG PART NUMBERS - 500070-500145-500386-500620**

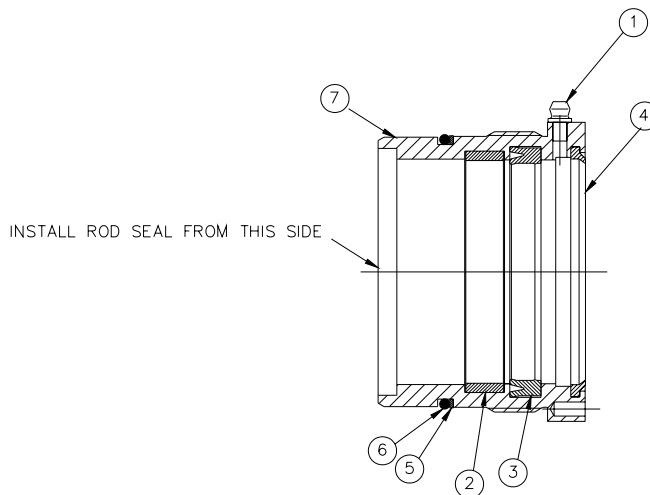

7	GUIDE, ROD, 16K JACK	1
6	RING, O, 16K JACK	1
5	WASHER, BACK-UP, 16K JACK	1
4	WIPER, ROD, 16K JACK	1
3	SEAL, ROD, T, 3.00, 16K JACK	1
2	RING, WEAR, ROD, 16K JACK	1
1	GREASE FITTING	1
ITEM	DESCRIPTION	QTY

**EXAMPLE OF A TYPICAL
ROD GUIDE CROSS SECTION DETAIL AND ORDER OF ASSEMBLY
LEG PART NUMBERS - 500070-500145-500386-500620**

SEAL REPLACEMENT KIT PART NUMBER -
800137S FOR 12000 LB. LEG - PART NUMBER
500385

SEAL REPLACEMENT KIT PART NUMBER
800131S FOR 16000 LB. LEGS - PART
NUMBERS 500070 & 500145

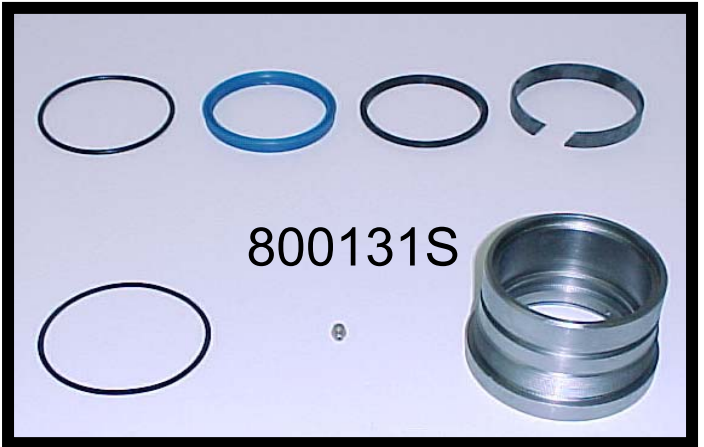
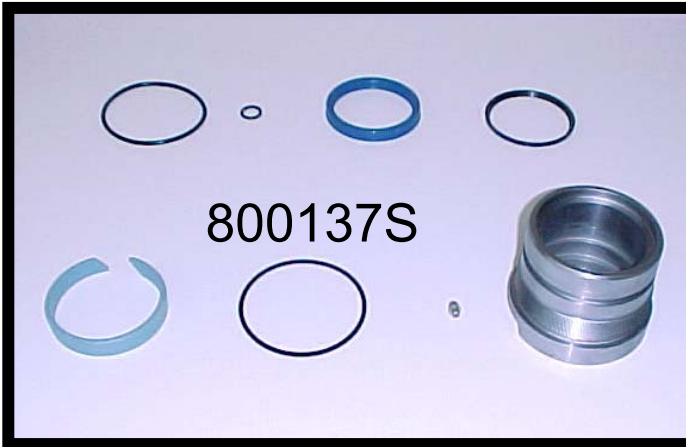

<u>QTY</u>	<u>PART #</u>	<u>DESCRIPTION</u>
	* included within 800149 Elastomer pkg	
* 1	01-1077	O-RING
* 1	01-1079	O-RING
* 1	02-1034	SEAL
* 1	03-1009	WIPER
* 1	04-1023	WEAR RING
* 1	05-1034	BACK-UP RING
* 1	02-1030	BOLT SEAL (not shown)
1	500680	ROD GUIDE
1	10-1002	GREASE FITTING

<u>QTY</u>	<u>PART #</u>	<u>DESCRIPTION</u>
	* included within 800146 Elastomer pkg	
* 1	01-1067	O-RING
* 1	02-1035	ROD GUIDE SEAL
* 1	03-1015	16K ROD WIPER
* 1	04-1019	ROD WEAR RING
* 1	05-1024	BACK-UP WASHER
1	10-1002	GREASE FITTING
1	500681	ROD GUIDE
* 1	02-1030	BOLT SEAL (not shown)

SEAL REPLACEMENT KIT PART NUMBER
800130S FOR 24000 LB. LEGS - PART
NUMBERS 500386 & 500620

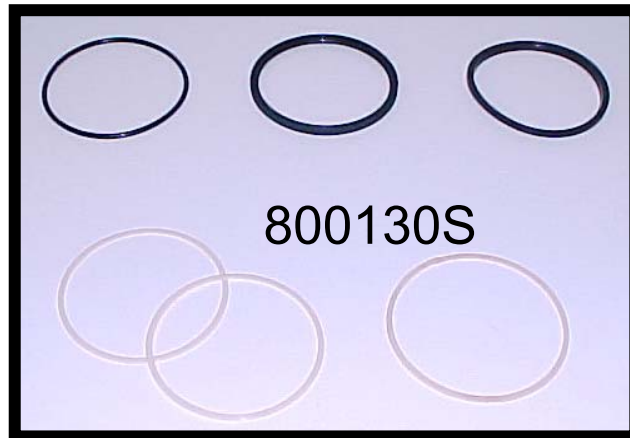

<u>QTY</u>	<u>PART #</u>	<u>DESCRIPTION</u>
	* included within 800157 Elastomer pkg	
* 1	01-1011	O-RING
* 1	02-1028	ROD GUIDE T-SEAL
* 1	03-1010	24K ROD WIPER
* 2	05-1035	BACK-UP WASHER
* 1	05-1036	BACK-UP WASHER
* 1	02-1019	THREAD SEAL (NOT PICTURED)

NOTE - (NOT SHOWN) PRESSURE WASH THE EXTERIOR OF THE LEG TO PREVENT DIRT FROM CONTAMINATING INTERIOR OF THE LEG DURING THE RE-ASSEMBLY PROCESS.



NOTE - IT MAY BE HELPFUL WHEN MOUNTING THIS JACK IN THE VISE TO ELEVATE THE FOOT END. THIS WILL PREVENT REMAINING OIL IN THE CYLINDER FROM DRAINING OUT WHEN THE ROD IS REMOVED.

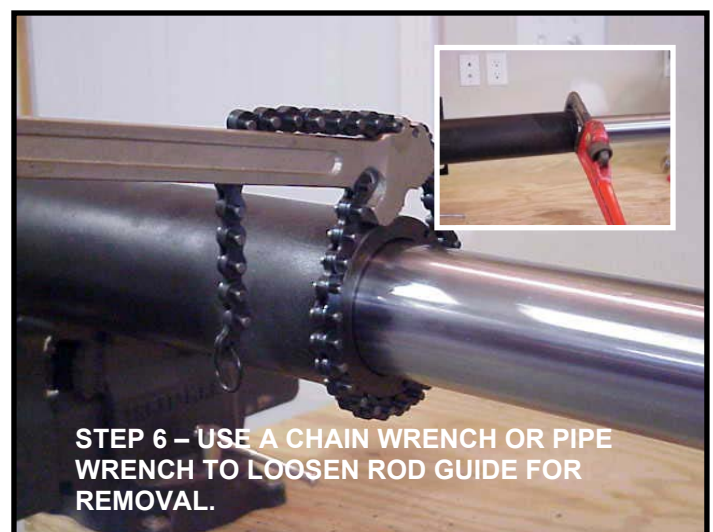
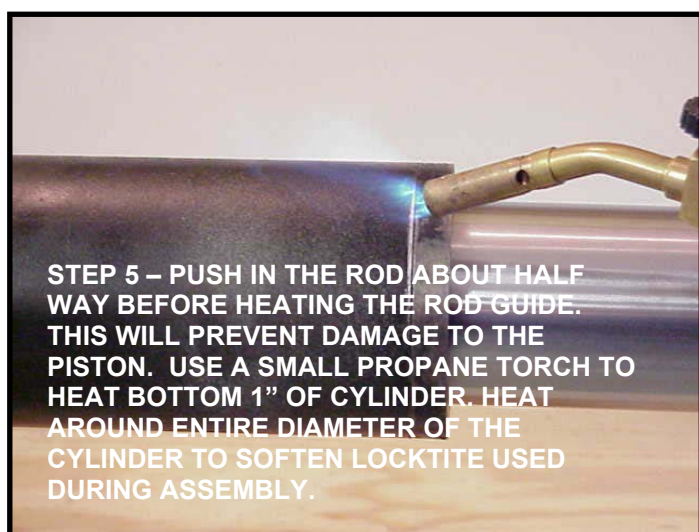
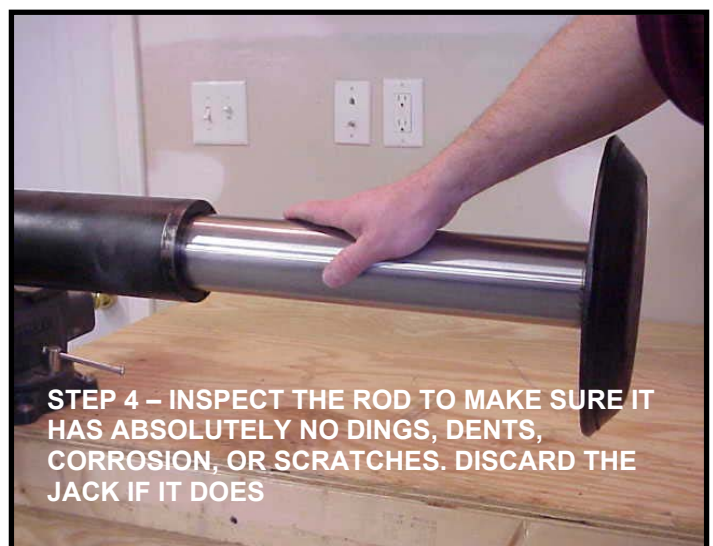

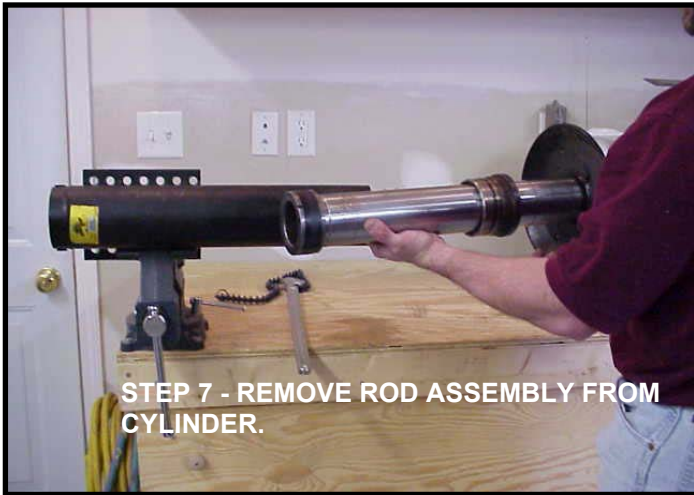

STEP 7 - REMOVE ROD ASSEMBLY FROM CYLINDER.



STEP 8 - SET FOOTPAD ON THE FLOOR. WITH SPANNER WRENCH, REMOVE PISTON FROM ROD. NOTE: SOME MODELS WILL HAVE THE PISTON HELD IN PLACE WITH A LARGE SNAP RING. REMOVE WITH APPROPRIATE SIZE EXTERNAL SNAP RING PLIERS

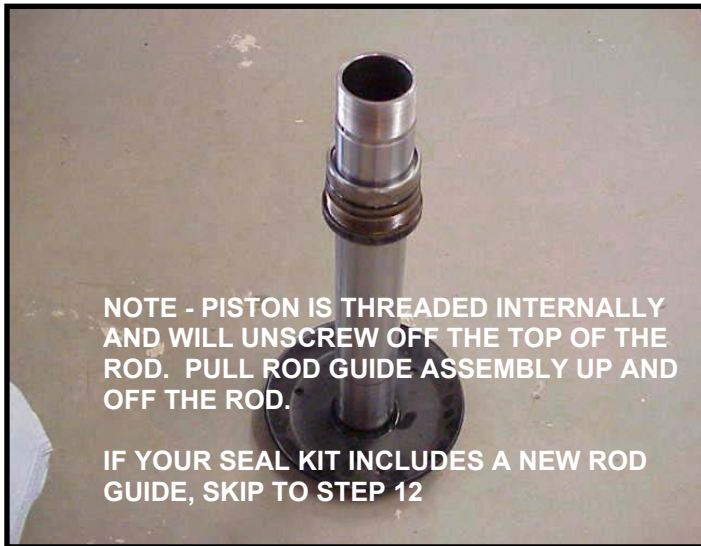

NOTE - PISTON IS THREADED INTERNALLY AND WILL UNSCREW OFF THE TOP OF THE ROD. PULL ROD GUIDE ASSEMBLY UP AND OFF THE ROD.

IF YOUR SEAL KIT INCLUDES A NEW ROD GUIDE, SKIP TO STEP 12



STEP 9 - WITH PICK TOOL REMOVE EXTERNAL O-RING AND BACK-UP RING FROM ROD GUIDE.



STEP 10 - WITH PICK TOOL REMOVE SEALS AND ANY BACK-UP RINGS.

NOTE - SEAL MAY BE EITHER T-TYPE OR V-TYPE SEAL.



STEP 11 - USING A WIRE BRUSH, CLEAN UP THE THREADS ON THE EXTERIOR OF THE ROD GUIDE. CLEAN THE LOWER INTERNAL PART OF THE ROD GUIDE IF NECESSARY.

NOTE - WIRE BRUSH DOES NOT NEED TO BE PNEUMATIC. ANY WIRE BRUSH CAN BE USED.

BE CAREFUL WHEN CLEANING THE INSIDE OF THE ROD GUIDE. THE SOFTER BEARING MATERIAL CAN BE DAMAGED.



STEP 12- USING A WIRE BRUSH, CLEAN UP THE THREADS ON THE EXTERIOR OF THE ROD WHERE THE PISTON IS THREADED.



STEP 13 - WITH THE PICK TOOL, REMOVE THE O-RING FROM THE 6 INCH BOLT.

NOTE: STEP 13 SHOWS AN O-RING FOR THE BOLT. ON OLDER JACK LEGS, PART # 500385, A 1/2" BOLT SEAL WAS USED INSTEAD OF AN O-RING. NOTE THE PART #: IF THE PART # READS 500385, WITH NO LETTER SUFFIX, THE SEAL MUST BE USED INSTEAD OF THE O-RING. PLEASE CHECK THE BILL OF MATERIALS ON PAGE 6 FOR THE PART NUMBER OF THE SEAL. THE SEAL WILL BE INCLUDED IN ALL KITS WITH PART # 800137S.



STEP 14- USING A WIRE BRUSH, CLEAN UP THE THREADS ON THE 6 INCH BOLT. INSTALL NEW O-RING.



STEP 15 - CLEAN ROD GUIDE (EVEN IF IT IS NEW).

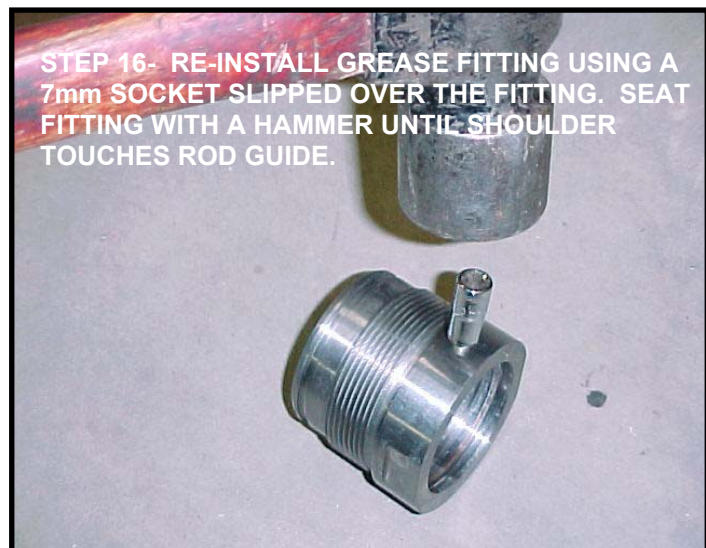

STEP 16- RE-INSTALL GREASE FITTING USING A 7mm SOCKET SLIPPED OVER THE FITTING. SEAT FITTING WITH A HAMMER UNTIL SHOULDER TOUCHES ROD GUIDE.



STEP 17 - LUBRICATE ALL SEALS WITH TRANSMISSION FLUID. INSTALL NEW WEAR RING INTO ROD GUIDE BY COMPRESSING UNTIL ENDS OVERLAP. INSTALL NEW O-RING AND BACK-UP WASHER ON EXTERIOR OF ROD GUIDE.

NOTE - MAKE SURE SEALS ARE INSTALLED IN THE PROPER DIRECTION. SEALS INSTALLED INCORRECTLY WILL CAUSE THE LEG TO FAIL. PLEASE NOTE THE CROSS SECTIONAL DRAWING OF THE ROD GUIDE ON PAGE 6 TO NOTE THE PROPER INSTALLATION OF THE SEALS AND RINGS.

NOTE - CHECK ORDER OF ASSEMBLY ON PAGE 6.

STEP 18 -INSTALL NEW SEAL. THE GROOVE IN A LIP SEAL WILL BE INSTALLED UP. ALWAYS INSTALL THE LIP SEAL FROM THE TOP SIDE OF THE ROD GUIDE TO AVOID CUTTING THE LIP UPON INSTALLATION.



NOTE - CLEAN ROD AND LUBRICATE IT WITH DEXRON III.

STEP 18A -IF YOUR SEAL KIT USES A "T-TYPE" SEAL INSTALL IT IN THE PROPER GROOVE. INSTALL NEW BACK-UP RING(S). MOST ROD GUIDES WILL HAVE THE UPPER BACK UP RING ELIMINATED TO PROMOTE FASTER RETRACTION.

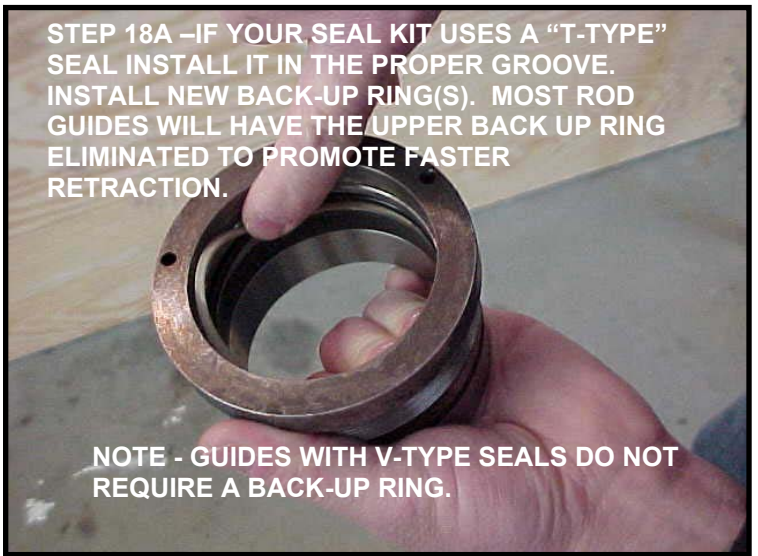

NOTE - GUIDES WITH V-TYPE SEALS DO NOT REQUIRE A BACK-UP RING.

STEP 20 - ASSEMBLE ROD GUIDE ONTO THE ROD THREAD SIDE UP. IF YOU HAVE A THREADED PISTON STYLE ROD, APPLY A 2"-3" BEAD OF LOCKTITE® TO THE THREADED PORTION OF THE ROD.



STEP 21 - THREAD PISTON ONTO THE ROD BY HAND UNTIL IT IS SEATED.

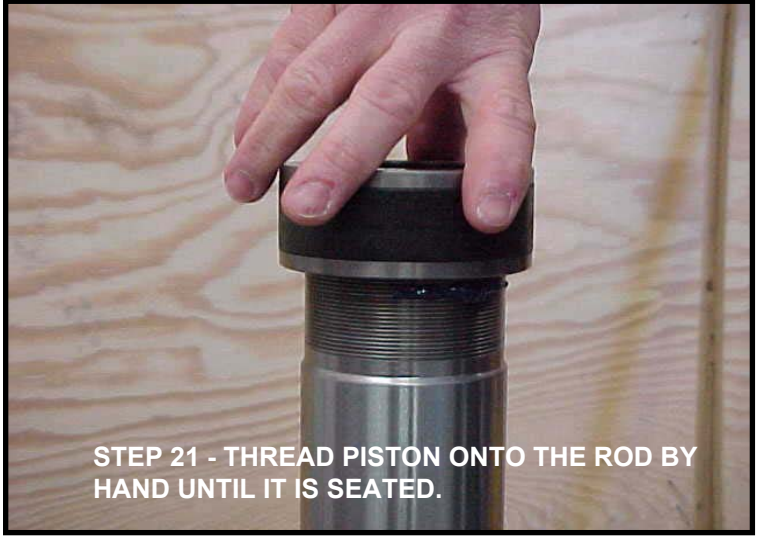

STEP 22 - USING A THE SPANNER WRENCH, TIGHTEN THE PISTON SNUGLY ON TO THE ROD. SNAP RING STYLE JACKS NEED THE SNAP RING INSTALLED AT THIS POINT.



STEP 23 - CLEAN THE INSIDE OF THE CYLINDER WITH A LINT FREE CLOTH. MAKE SURE THERE IS ABSOLUTLEY NO DEBRIS OR OLD LOCKTITE LEFT INSIDE THE CYLINDER.

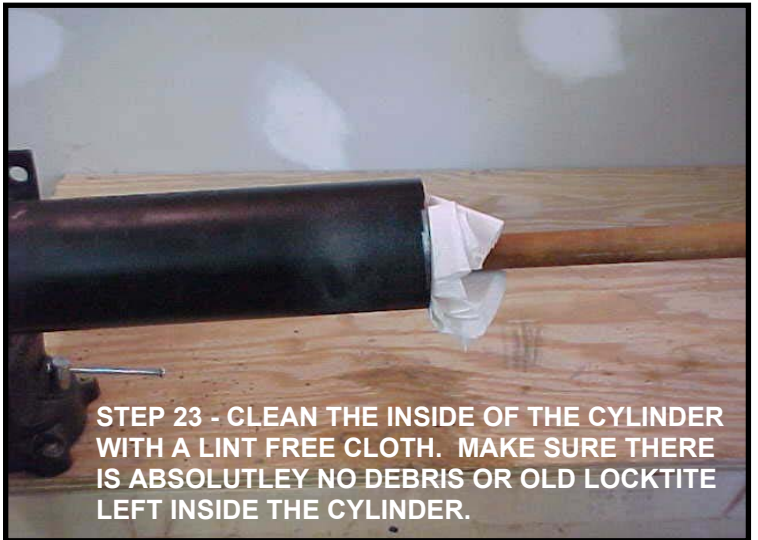



STEP 24 - INSERT THE PISTON BACK INTO THE CYLINDER.

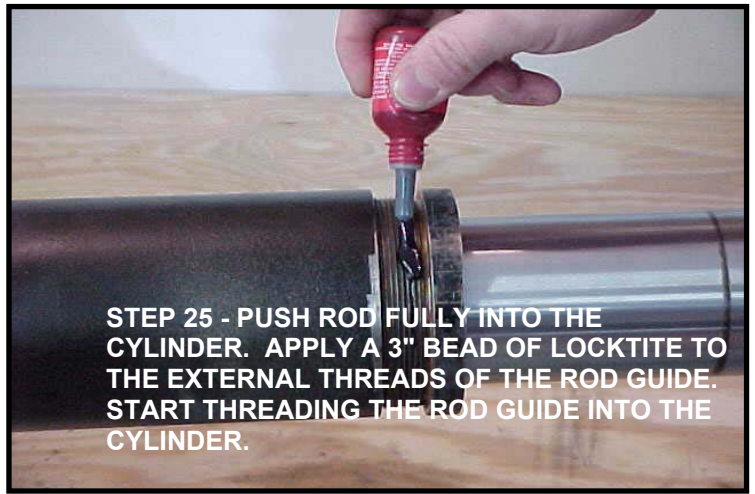

STEP 25 - PUSH ROD FULLY INTO THE CYLINDER. APPLY A 3" BEAD OF LOCKTITE TO THE EXTERNAL THREADS OF THE ROD GUIDE. START THREADING THE ROD GUIDE INTO THE CYLINDER.



STEP 26- USING THE CHAIN WRENCH, TIGHTEN ROD GUIDE INTO CYLINDER.

NOTE - NOTICE IN THE INSET PICTURE THAT THE ROD GUIDE IS SEATED SNUGLY TO THE CYLINDER.



STEP 27 - APPLY 2" OF LOCKTITE TO THE THREADS IN THE MIDDLE OF THE 6" BOLT.

STEP 28- INSTALL THE BOLT AND TIGHTEN. TORQUE TO 45 FT/LB.

NOTE – PAINT THE RODE GUIDE ONCE THE JACK IS COMPLETELY REASSEMBLED. GREASE THE ROD GUIDE. RE-INSTALL LEG ON THE COACH AND TEST TO OPERATE. FLUSH AND REFILL THE HYDRAULIC SYSTEM WITH FRESH FLUID (DEXTRON III). CYCLE EACH LEG 2-3 TIMES FROM FULL EXTENSION TO FULL RETRACTION AFTER FILLING RESERVOIR TO PURGE AIR FROM THE SYSTEM. BE SURE TO CHECK FLUID LEVEL AFTER EACH CYCLE OF THE LEGS.

EXTERNAL SPRING LEGS

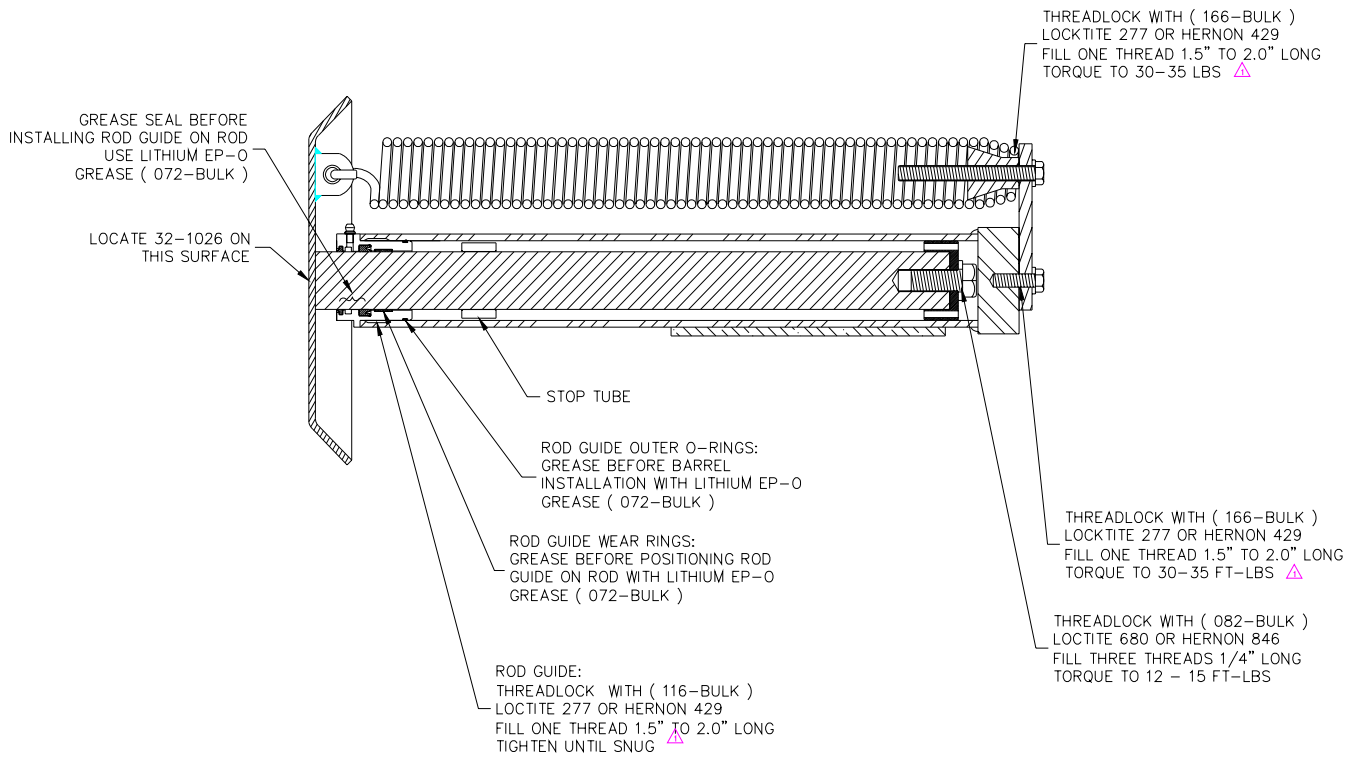

EXAMPLE OF A TYPICAL ROD GUIDE CROSS SECTION DETAIL AND ORDER OF ASSEMBLY

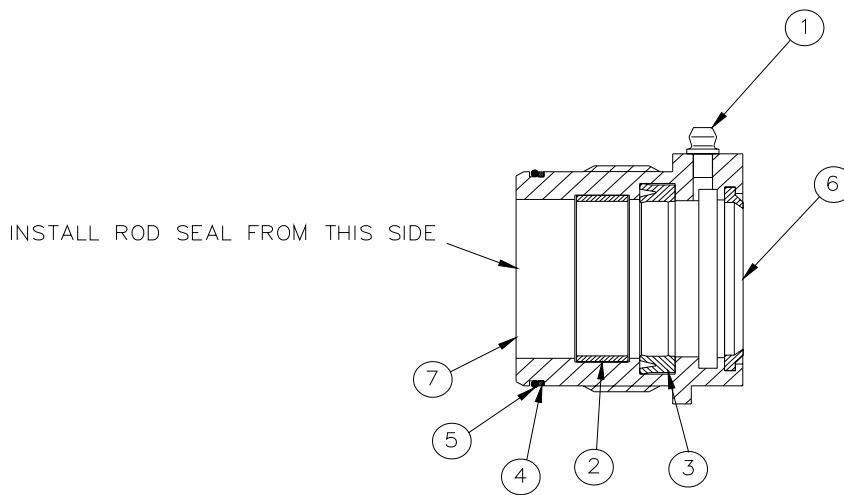

7	GUIDE, ROD, 6K JACK	1
6	WIPER, ROD, 6K JACK	1
5	RING, O, 2.25 O.D. 6K JACK	1
4	WASHER, BACK-UP, 2.25 6K JACK	1
3	SEAL, ROD, 1.625, 6K JACK	1
2	RING, WEAR, ROD, 6K JACK	1
1	GREASE FITTING	1
ITEM	DESCRIPTION	QTY

SEAL REPLACEMENT KIT PART NUMBER:

800129S
FOR 9000 LBS. LEGS – PART NUMBERS
500082, 500082H, 500082HR, 500146,
500235, 500272

800132S
FOR 6000 LBS. LEGS (2001 –PRESENT)
PART NUMBERS: 500384, 500384H,
500384HR & 500482

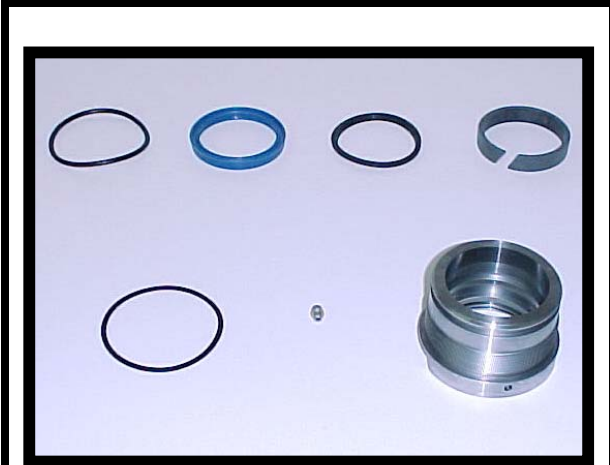

800129S CONTENTS

* included within 800145 Elastomer pkg

QTY	PART #	DESCRIPTION
* 1	01-1071	O-RING
* 1	02-1032	U-CUP SEAL
* 1	03-1012	ROD WIPER
* 1	04-1017	ROD WEAR RING
* 1	040-1030	ROD WEAR RING
* 1	05-1027	BACK UP WASHER
1	500602	ROD GUIDE
1	10-1002	GREASE FITTING
* 1	030-1020	O-RING
* 1	050-1041	BACK UP RING

The 800129S kit will include 2 similar looking rod guide wear rings. One is thicker than the other. If you are re-sealing an “HR” series jack, use the thicker wear ring



800132S CONTENTS

** included within 800285 “HR” KIT

* included with 800147 Elastomer pkg.

QTY	PART #	DESCRIPTION
* 1	01-1078	O-RING
* 1	02-1033	U-CUP SEAL
* 1	03-1013	ROD WIPER SEAL
* 1	04-1028	ROD WEAR RING
* 1	05-1037	BACK UP WASHER
1	10-1002	GREASE FITTING
1	500679	ROD GUIDE
1	500497	PISTON GUIDE
** 1	030-1019	O-RING
** 1	050-1040	BACK UP WASHER
** 1	01-1078	O-RING
** 1	05-1037	O-RING
** 1	500752C	ROD GUIDE
** 1	500756	SEAL
** 1	500757	ROD WIPER SEAL
** 1	500758	WEAR RING-ROD

The 800132S kit will have a separate kit within the box labeled 800285. Use components in this kit for HR style jacks.



Kit numbers 800129S and 800132S include parts for two different style jacks. When re-assembling the jack you will need to determine which style you are working on. Use the following guidelines to choose the correct components: There are a few different ways to determine that you are working on an “HR” series jack.

1. If the jack part number ends with the letters HR.
2. HR jacks have a #4 JIC hose fitting. Non “HR” jacks use a #6 JIC.
3. If the **piston** looks like the one pictured to the left, then it is an HR series jack.

STEP 1 - (NOT SHOWN) PRESSURE WASH THE EXTERIOR OF THE LEG TO PREVENT DIRT FROM CONTAMINATING INTERIOR OF THE LEG DURING THE REASSEMBLY PROCESS.

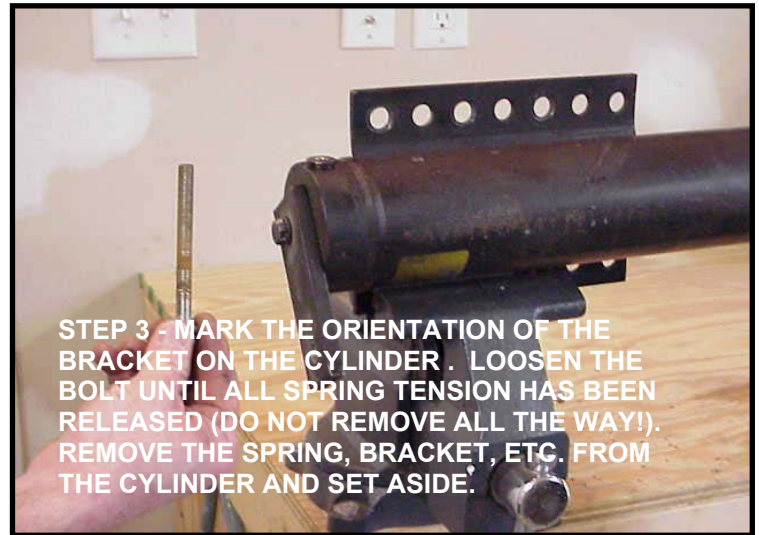

NOTE - IT MAY BE HELPFUL WHEN MOUNTING THIS JACK IN THE VISE TO ELEVATE THE FOOT END. THIS WILL PREVENT REMAINING OIL IN THE CYLINDER FROM DRAINING OUT WHEN THE ROD IS REMOVED.

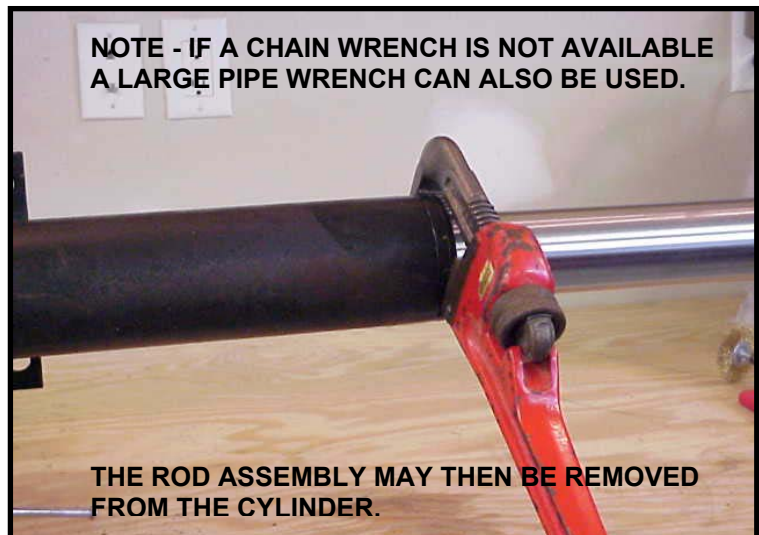
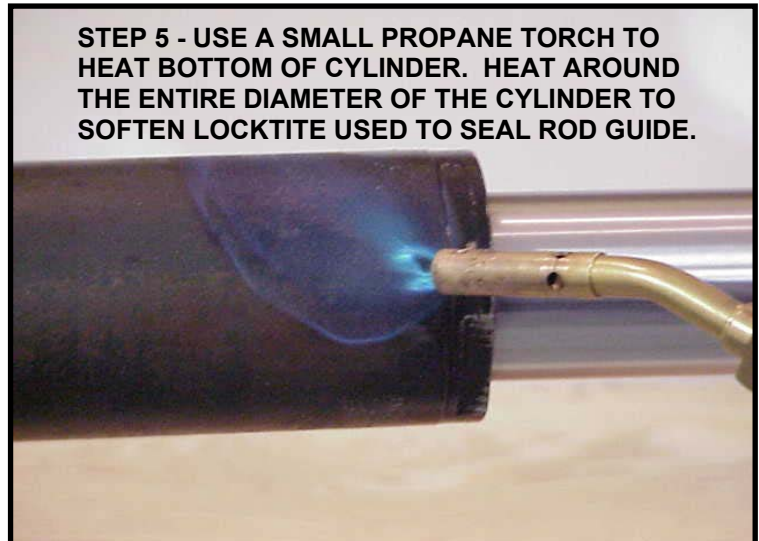
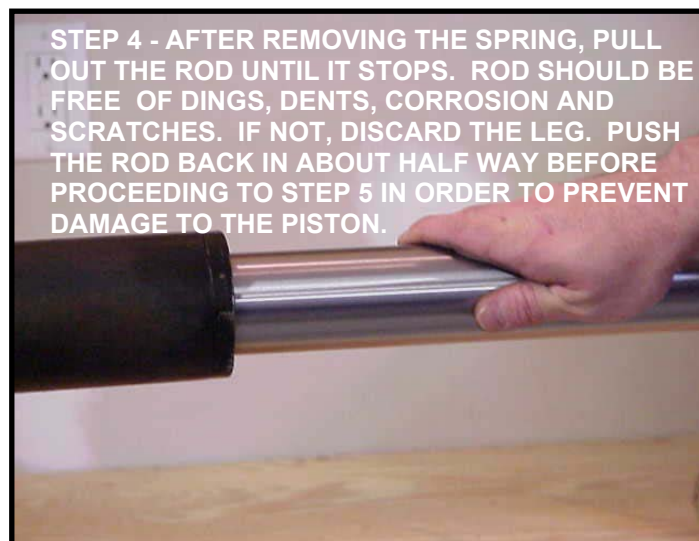

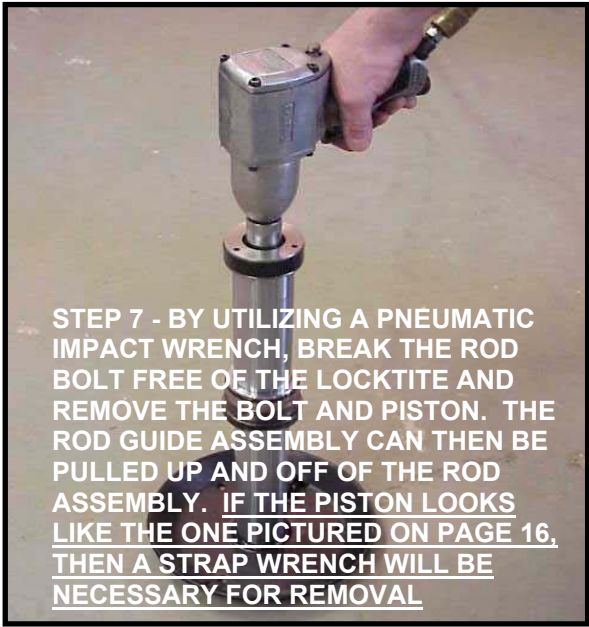

STEP 7A- HR STYLE JACKS WILL USE A PISTON WHICH REQUIRES A STRAP WRENCH TO REMOVE

SKIP TO STEP 11 IF YOU ARE SUPPLIED WITH A NEW ROD GUIDE.

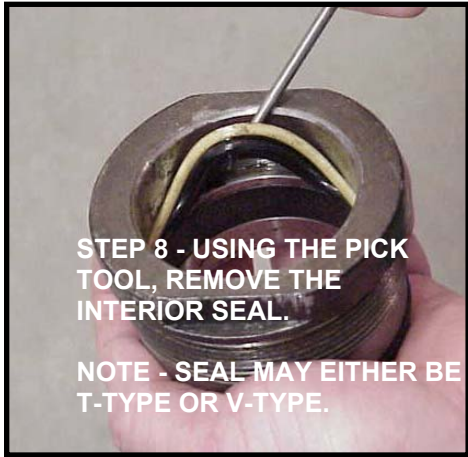

NOTE - MAKE SURE SEALS ARE INSTALLED IN THE PROPER DIRECTION. SEALS INSTALLED INCORRECTLY WILL CAUSE THE LEG TO FAIL. PLEASE NOTE THE CROSS SECTIONAL DRAWING OF THE ROD GUIDE ON PAGES 14 AND 15 TO NOTE THE PROPER INSTALLATION OF THE SEALS AND RINGS.

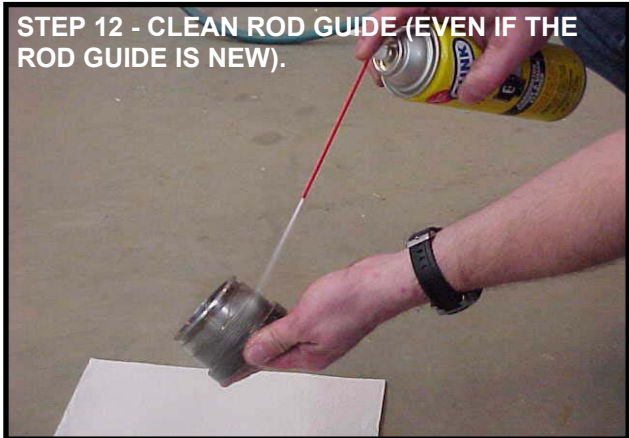

NOTE - WIRE BRUSH DOES NOT NEED TO BE PNEUMATIC. ANY WIRE BRUSH CAN BE USED. BE CAREFUL NOT TO DAMAGE THE SOFT BEARING MATERIAL.

NOTE - CHECK ORDER OF ASSEMBLY ON PAGE 14.

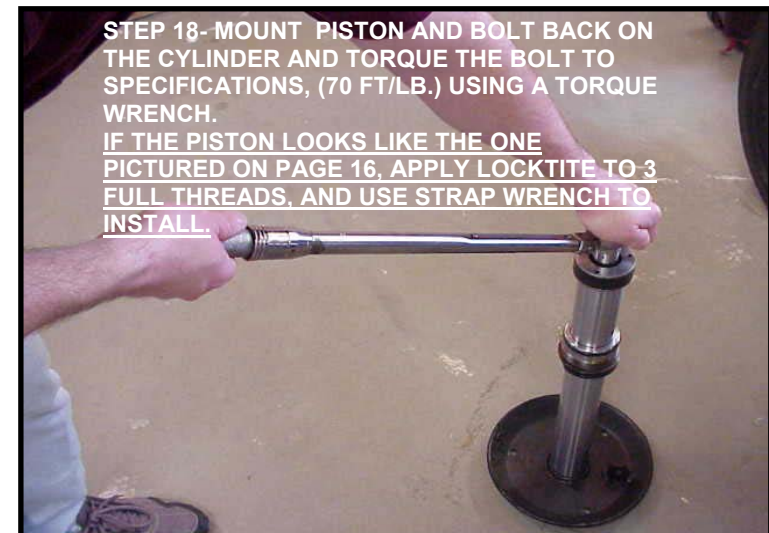
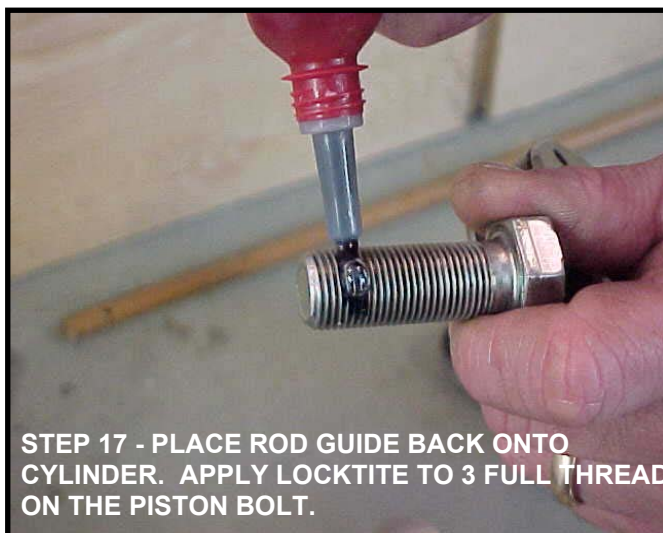
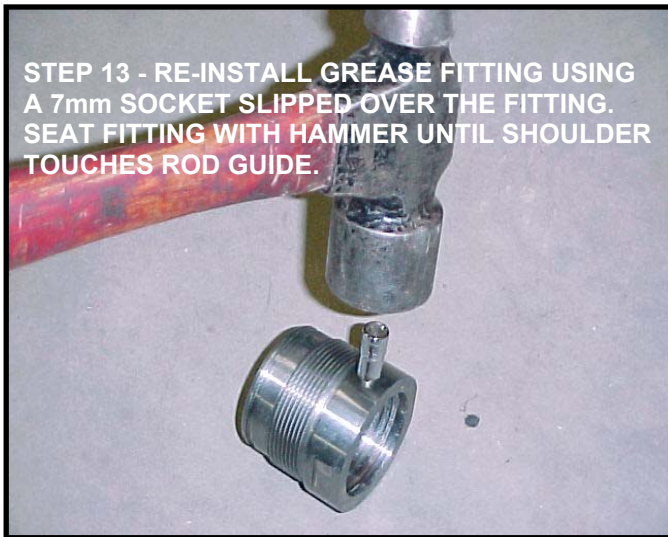

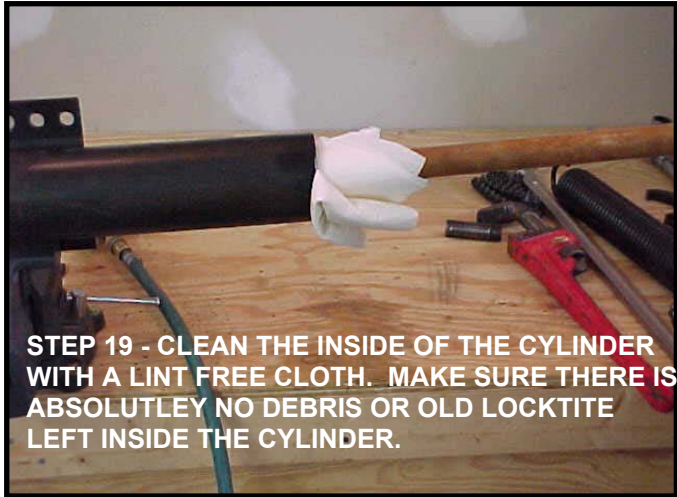

STEP 19 - CLEAN THE INSIDE OF THE CYLINDER WITH A LINT FREE CLOTH. MAKE SURE THERE IS ABSOLUTLEY NO DEBRIS OR OLD LOCKTITE LEFT INSIDE THE CYLINDER.



STEP 20 - INSERT THE ROD ASSEMBLY BACK INTO THE CYLINDER.



STEP 21 - APPLY A 2" BEAD OF LOCKTITE TO THE ROD GUIDE THREADS.



STEP 22 - THREAD THE ROD GUIDE INTO THE CYLINDER AND TIGHTEN UNTIL SNUG.



STEP 23 - FILL 3 THREADS ON THE BRACKET BOLT WITH LOCKTITE AND TORQUE TO 20 FT/LB.



STEP 24 - REASSEMBLE SPRING AND BRACKET. INSTALL JACK ONTO COACH AND TEST.

NOTE - GREASE THE ROD GUIDE AND PAINT THE ROD GUIDE AREA ONCE THE JACK HAS BEEN FULLY ASSEMBLED. RE-INSTALL LEG ON THE COACH AND TEST TO OPERATE. FLUSH AND REFILL THE HYDRAULIC SYSTEM WITH FRESH FLUID (DEXTRON III). CYCLE EACH LEG 2-3 TIMES FROM FULL EXTENSION TO FULL RETRACTION TO PURGE AIR FROM THE SYSTEM. BE SURE TO CHECK FLUID LEVEL AFTER EACH CYCLE OF THE LEGS.

POWER LEVEL HYDRAULIC LEGS

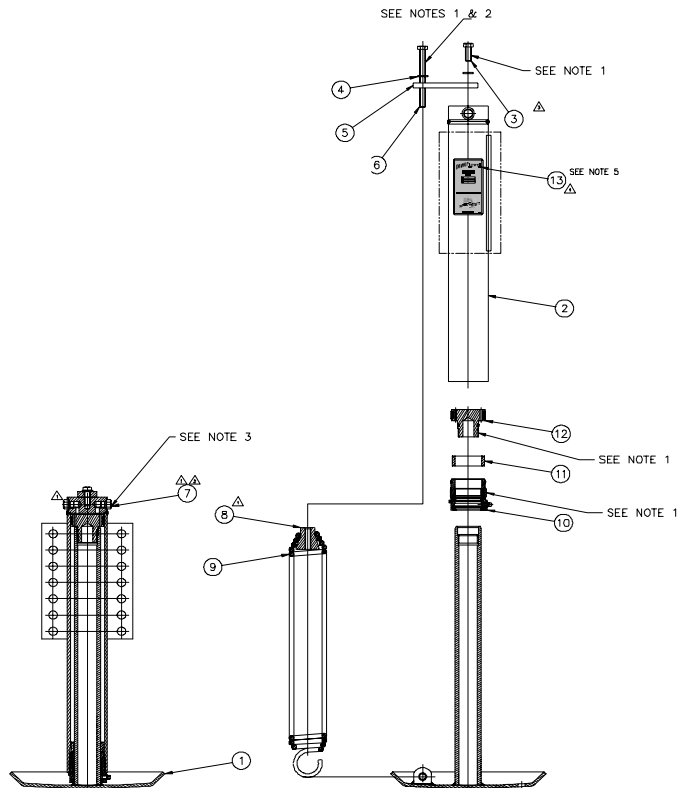

**EXAMPLE OF A TYPICAL
POWER GEAR POWER LEVEL HYDRAULIC LEG CROSS SECTION DETAIL
LEG PART NUMBERS - 500759-500833-500843**

INSTALL SEAL 605 FROM THIS END

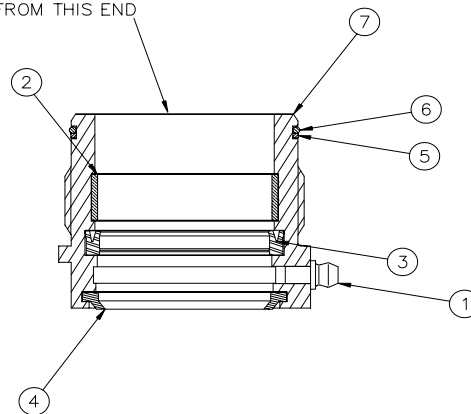

7	ROD GUIDE 1.75 ROD HOLLOW	1
6	O-RING 2.25 O.D. 9K-LW JACK	1
5	BACK-UP WASHER 2.25 9K LW JACK	1
4	WIPER, ROD, 9K-LW JACK 1.75 DIA.	1
3	SEAL 605 1.75	1
2	WEAR RING 1.75 DIA. ROD	1
1	GREASE FITTING	1
ITEM	DESCRIPTION	QTY

**EXAMPLE OF A TYPICAL
ROD GUIDE CROSS SECTION DETAIL AND ORDER OF ASSEMBLY
LEG PART NUMBERS - 500759-500833-500843**

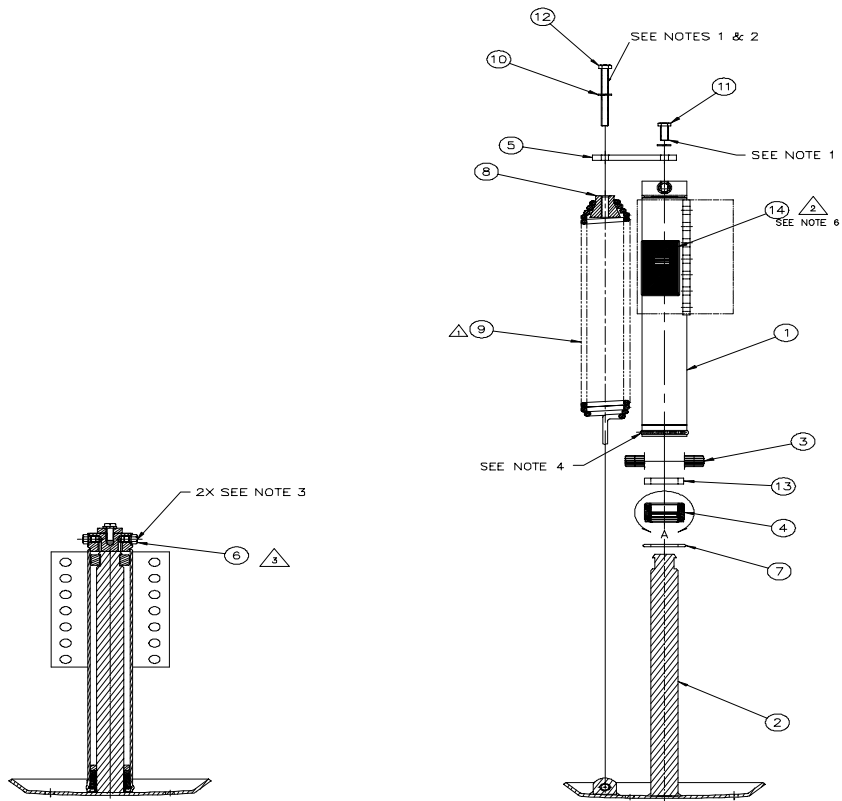

**EXAMPLE OF A TYPICAL
POWER GEAR POWER LEVEL HYDRAULIC LEG CROSS SECTION DETAIL
LEG PART NUMBERS - 500730-500832-500842**

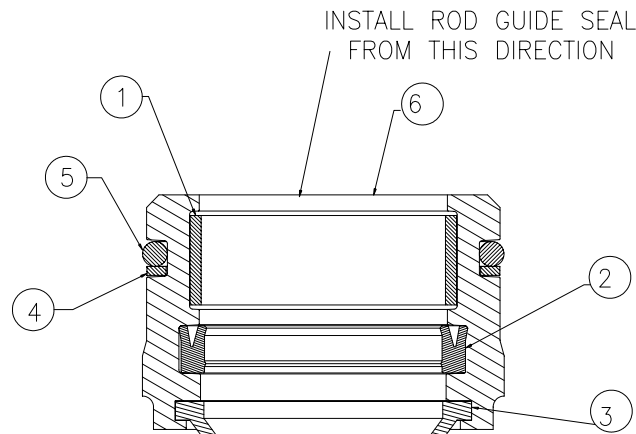

6	6K ROD GUIDE	1
5	O-RING	1
4	BACK-UP WASHER	1
3	ROD WIPER 1.375	1
2	ROD GUIDE SEAL	1
1	WEAR RING 1.375	1
ITEM#	DESCRIPTION	QTY

**EXAMPLE OF A TYPICAL 6K JACK ROD GUIDE
CROSS SECTION DETAIL AND ASSEMBLY ORDER
LEG PART NUMBERS - 500730-500832-500842**

**SEAL REPLACEMENT KIT PART NUMBER – 800133S
FOR 6000 LBS. POWER LEVEL LEGS – PART NUMBERS – 500730, 500832, 500842, 500933**

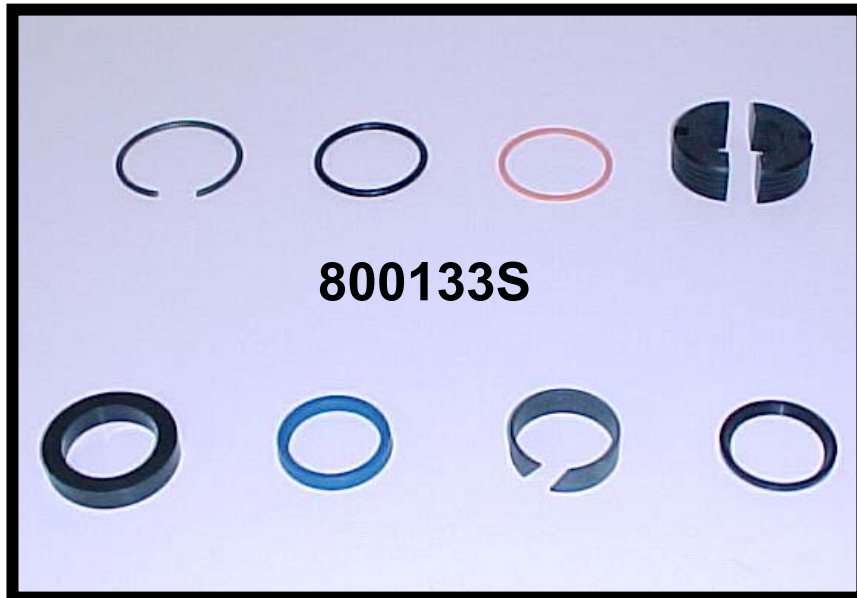

* included within 800148 Elastomer pkg

QTY	PART #	DESCRIPTION
1	A8121049	RETAINING RING
* 1	01-1009	O-RING
* 1	05-1020	BACK-UP WASHER
2	500734	PISTON
1	500739	NYLON STOP
* 1	500746	ROD GUIDE SEAL
* 1	500747	WEAR RING
* 1	500748	ROD WIPER

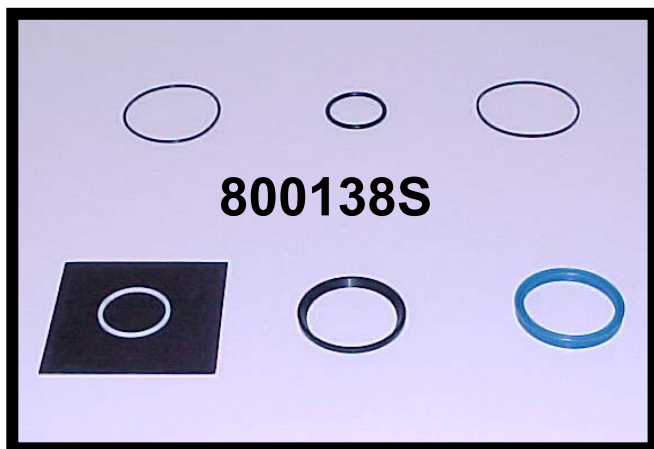

* included within 800150 Elastomer pkg

QTY	PART #	DESCRIPTION
* 1	01-1078	O-RING
* 1	030-1019	O-RING
* 1	050-1040	TEFLON BACK-UP RING
* 1	05-1037	BACK-UP RING
* 1	500756	ROD GUIDE SEAL
* 1	500757	ROD WIPER
1	10-1002	GREASE FITTING



* included within 800200 Elastomer pkg

QTY	PART #	DESCRIPTION
* 1	01-1071	O-RING
* 1	02-1032	U-CUP SEAL
* 1	03-1012	ROD WIPER
* 1	030-1020	O-RING
* 1	040-1029	PISTON WEAR RING
* 1	040-1030	ROD WEAR RING
* 1	05-1027	BACK UP WASHER
* 1	050-1041	BACK UP RING
1	10-1002	GREASE FITTING

NOTE -THE FOLLOWING DISASSEMBLY PROCEDURE IS FOR 6K LEGS. 9 AND 12K LEGS WILL USE THE SAME REBUILD PROCEDURE AS ON EXTERNAL SPRING STYLE LEGS. (NOT SHOWN) PRESSURE-WASH THE EXTERIOR OF THE LEG TO PREVENT DIRT FROM CONTAMINATING INTERIOR OF THE LEG DURING THE RE-ASSEMBLY PROCESS.



NOTE - IT MAY BE HELPFUL WHEN MOUNTING THIS JACK IN THE VISE TO ELEVATE THE FOOT END. THIS WILL PREVENT REMAINING OIL IN THE CYLINDER FROM DRAINING OUT WHEN THE ROD IS REMOVED.

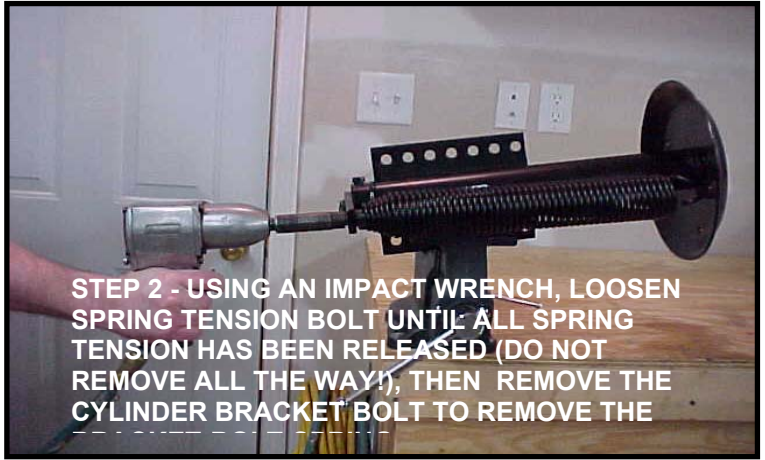

STEP 2 - USING AN IMPACT WRENCH, LOOSEN SPRING TENSION BOLT UNTIL ALL SPRING TENSION HAS BEEN RELEASED (DO NOT REMOVE ALL THE WAY!), THEN REMOVE THE CYLINDER BRACKET BOLT TO REMOVE THE



NOTE - WHEN SPRING TENSION AND BRACKET BOLT HAVE BEEN REMOVED, THE ENTIRE SPRING/BRACKET ASSEMBLY CAN BE REMOVED.

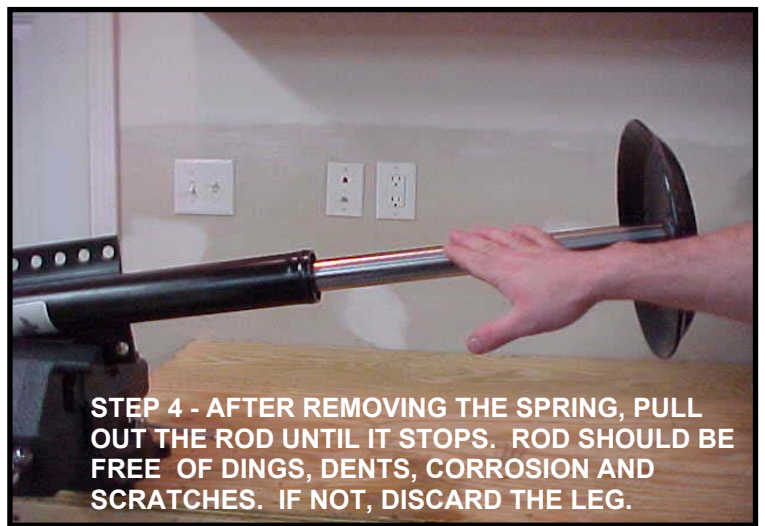

STEP 4 - AFTER REMOVING THE SPRING, PULL OUT THE ROD UNTIL IT STOPS. ROD SHOULD BE FREE OF DINGS, DENTS, CORROSION AND SCRATCHES. IF NOT, DISCARD THE LEG.



STEP 5 - USE A 1/4" DRIFT PUNCH TO GENTLY DRIVE THE ROD GUIDE IN TOWARDS TOP OF CYLINDER.



STEP 6 - USE A 1/8" OR SMALLER DRIFT PIN PUNCH TO LOOSEN THE RETAINING RING.

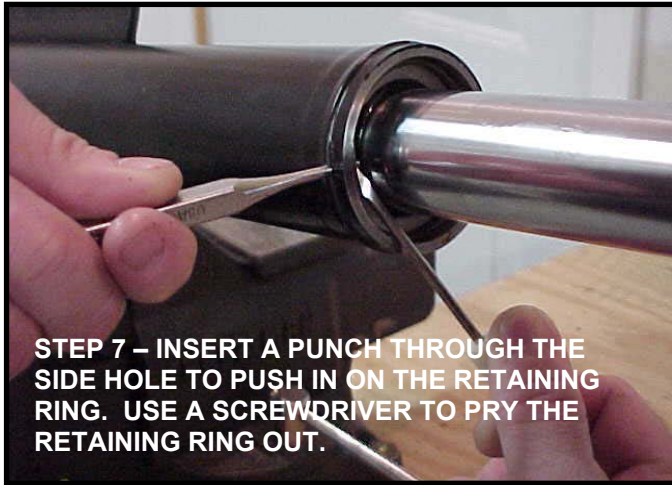

STEP 7 – INSERT A PUNCH THROUGH THE SIDE HOLE TO PUSH IN ON THE RETAINING RING. USE A SCREWDRIVER TO PRY THE RETAINING RING OUT.

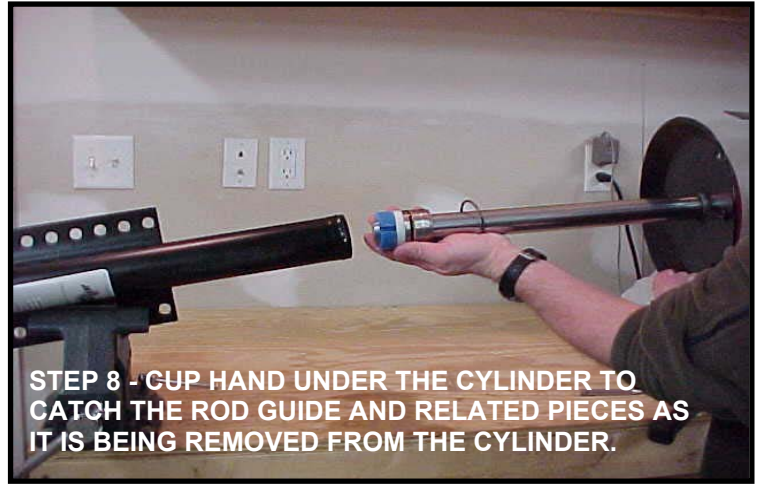

STEP 8 - GUP HAND UNDER THE CYLINDER TO CATCH THE ROD GUIDE AND RELATED PIECES AS IT IS BEING REMOVED FROM THE CYLINDER.



STEP 9 - REMOVE PLASTIC PISTON FROM END OF ROD. PISTON WILL COME OFF IN TWO PIECES.



STEP 10 - USE A SUITABLE TOOL TO REMOVE BOTH SEALS FROM THE ROD GUIDE.

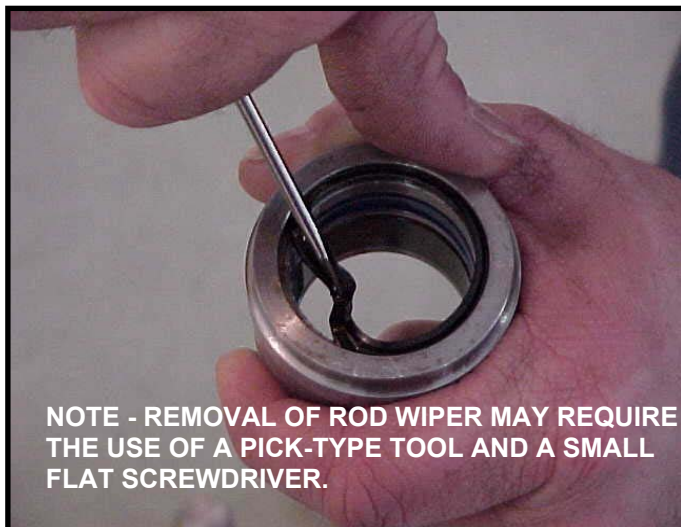

NOTE - REMOVAL OF ROD WIPER MAY REQUIRE THE USE OF A PICK-TYPE TOOL AND A SMALL FLAT SCREWDRIVER.

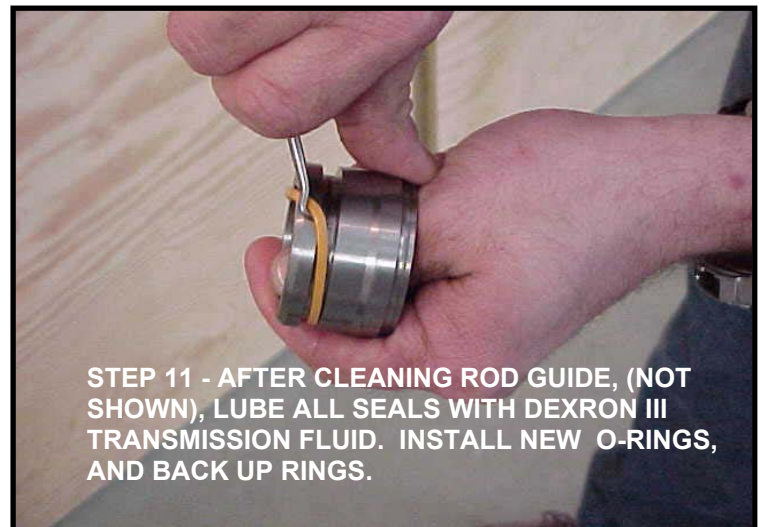

STEP 11 - AFTER CLEANING ROD GUIDE, (NOT SHOWN), LUBE ALL SEALS WITH DEXRON III TRANSMISSION FLUID. INSTALL NEW O-RINGS, AND BACK UP RINGS.

NOTE - MAKE SURE SEALS ARE INSTALLED IN THE PROPER DIRECTION. SEALS INSTALLED INCORRECTLY WILL CAUSE THE LEG TO FAIL. PLEASE NOTE THE CROSS SECTIONAL DRAWING OF THE ROD GUIDE ON PAGES 21 AND 22 TO NOTE THE PROPER INSTALLATION OF THE SEALS AND RINGS.

NOTE - BE SURE BACK-UP AND O-RINGS ARE ORIENTED CORRECTLY AND IN THE PROPER ORDER ON THE ROD GUIDE. REFER TO CROSS SECTION DETAIL OF ROD GUIDE AT BEGINNING OF THIS SECTION.

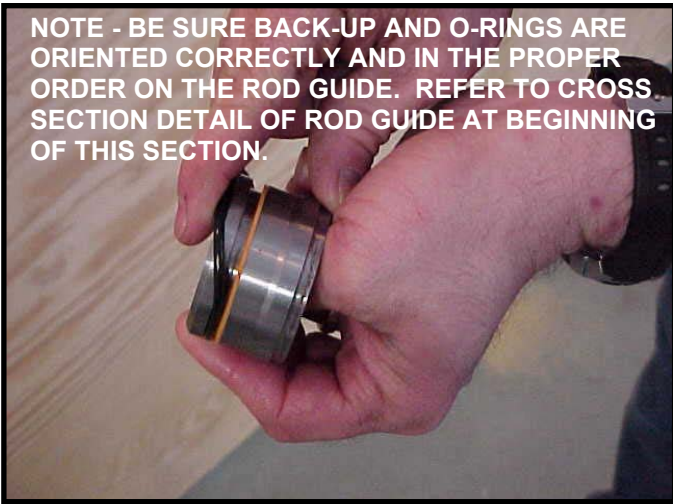

STEP 12-INSTALL THE NEW WEAR RING BY COMPRESSING IT UNTIL THE ENDS OVERLAP. INSTALL NEW LIP SEAL WITH THE GROOVE POINTED UP. INSTALL FROM THE TOP SIDE TO PREVENT DAMAGE TO THE SEAL EDGES.



STEP 13 - INSTALL WIPER SEAL. MAKE SURE SEAL IS ORIENTED PROPERLY. FAILURE TO DO SO WILL CAUSE THE LEG TO FAIL.



STEP 14 - CLEAN INTERIOR OF LEG CYLINDER. USE A DUSTLESS CLOTH OR SHOP RAG. BE SURE TO REMOVE ALL DEBRIS.



STEP 15 - REPLACE ROD GUIDE ON TO ROD. REPLACE BOTH PIECES OF THE PISTON AND CUP THE REASSEMBLED ROD GUIDE IN YOUR HAND. INSERT THE ROD ASSEMBLY BACK INTO THE CYLINDER.

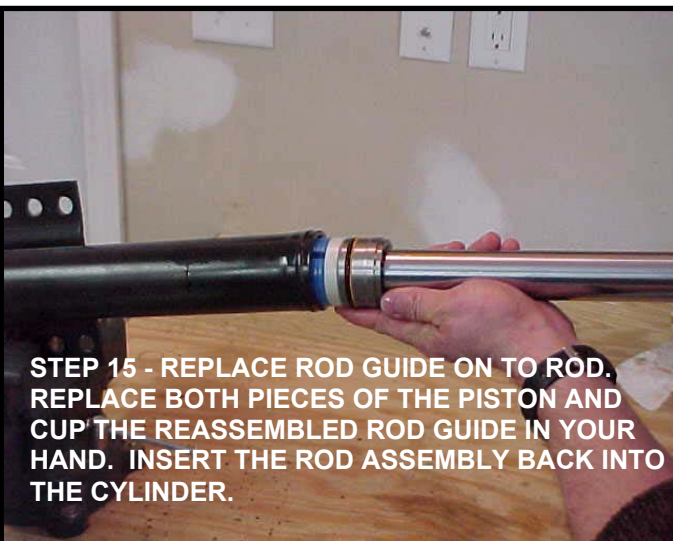

STEP 16 - REPLACE RETAINING RING IN THE EXACT SPOT FROM WHICH IT WAS REMOVED. MAKE SURE PUNCH HOLE IS NOT SETTING IN THE RETAINING RING'S GAP.



NOTE - MAKE SURE SEALS ARE INSTALLED IN THE PROPER DIRECTION. SEALS INSTALLED INCORRECTLY WILL CAUSE THE LEG TO FAIL. PLEASE NOTE THE CROSS SECTIONAL DRAWING OF THE ROD GUIDE ON PAGES 20 AND 21 TO NOTE THE PROPER INSTALLATION OF THE SEALS AND RINGS.

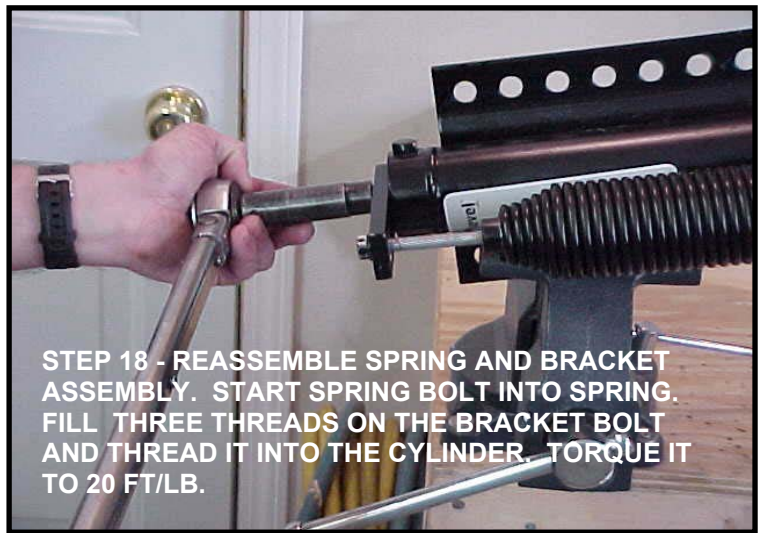
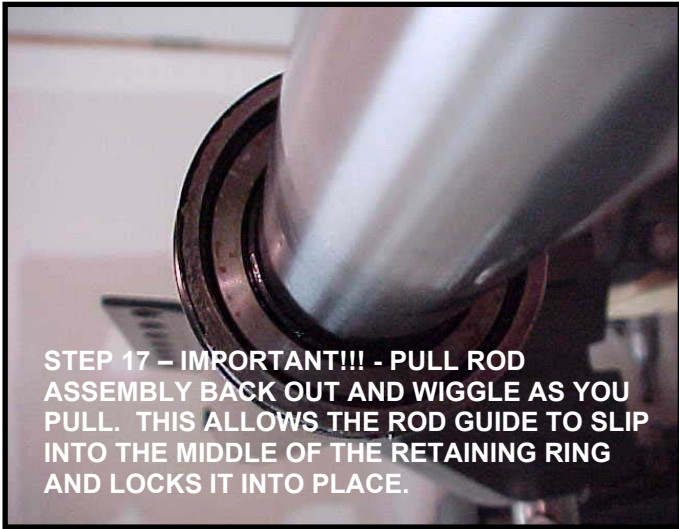

NOTE - RE-INSTALL LEG ON THE COACH AND TEST TO OPERATE. FLUSH AND REFILL THE HYDRAULIC SYSTEM WITH FRESH FLUID (DEXTRON III). CYCLE EACH LEG 2-3 TIMES AFTER FILLING RESERVOIR TO PURGE AIR FROM THE SYSTEM AND PUSH THE FLUID THROUGH THE LINES. BE SURE TO CHECK FLUID LEVEL AFTER EACH CYCLE OF THE LEGS.



**1217 E. 7TH St.
Mishawaka, IN 46544
(800) 334-4712**