

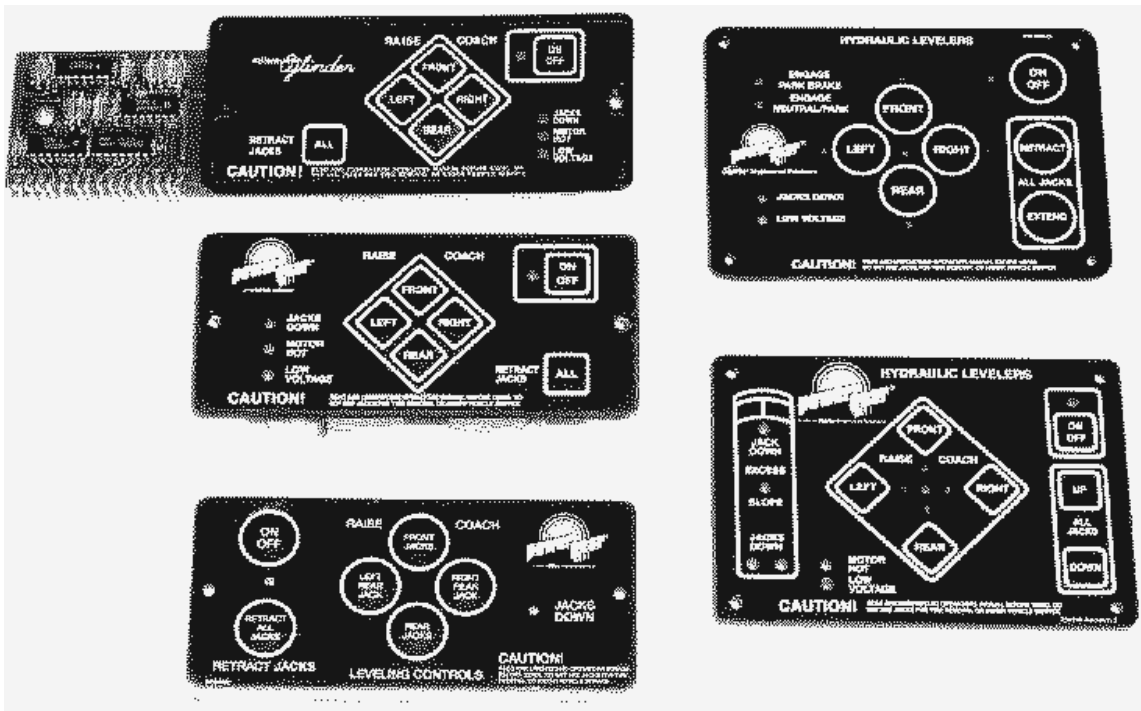

# PARTS AND SERVICE MANUAL

FOR LEVELING SYSTEMS WITH TOUCH PAD PART NUMBERS  
500089, 500105, 500210, 500456, 500535 or no number at all



Visit us on the web at [www.powergearus.com](http://www.powergearus.com)!

82-L0051-00  
Rev. 3

# WARNING

- **DO NOT USE THE POWER GEAR HYDRAULIC LEVELING SYSTEM (OR AIR SUSPENSION) TO SUPPORT VEHICLE WHILE UNDER COACH OR CHANGING TIRES. THE HYDRAULIC LEVELING SYSTEM IS DESIGNED AS A 'LEVELING' SYSTEM ONLY. TIRE REPAIRS SHOULD BE PERFORMED BY A TRAINED PROFESSIONAL. ATTEMPTS TO CHANGE TIRES WHILE SUPPORTING THE VEHICLE WITH THE HYDRAULIC SYSTEM COULD RESULT IN DAMAGE TO THE MOTOR HOME AND/OR CAUSE SERIOUS INJURY OR EVEN DEATH.**
- **KEEP PEOPLE CLEAR OF COACH WHILE LEVELING SYSTEM IS IN USE.**
- **NEVER LIFT THE WHEELS OFF THE GROUND TO LEVEL THE COACH. DOING SO MAY CREATE AN UNSTABLE CONDITION.**
- **NEVER EXPOSE HANDS OR OTHER PARTS OF THE BODY NEAR HYDRAULIC LEAKS. HIGH PRESSURE OIL LEAKS MAY CUT AND PENETRATE THE SKIN CAUSING SERIOUS INJURY.**

CAUTION - PARK THE COACH ON A REASONABLY SOLID SURFACE OR THE JACKS MAY SINK INTO GROUND. ON SOFT SURFACES, USE LOAD DISTRIBUTION PADS UNDER EACH JACK.

CAUTION - CHECK THAT POTENTIAL JACK CONTACT LOCATIONS ARE CLEAR OF OBSTRUCTIONS OR DEPRESSIONS BEFORE OPERATION.

## **BEFORE YOU OPERATE THE SYSTEM:**

The leveling system shall only be operated under the following conditions:

1. The coach is parked on a reasonably level surface.
2. The coach "PARKING BRAKE" is engaged.
3. The coach transmission should be in the neutral or park position.
4. The ignition is in the run position, or engine is running.

## **SYSTEM DESCRIPTION**

**Please read and study the operating manual before you operate the leveling system.**

**SYSTEM DESCRIPTION** - The Power Gear electro-hydraulic leveling system consists of the following major components:

- (A)** Spring return jacks rated at a lifting capacity appropriate for your coach. Each jack has a large 10" diameter (78.5 square inch) shoe for maximum surface area on soft surfaces.
- (B)** Each jack is powered from a central 12VDC motor/pump assembly, which also includes the hydraulic oil reservoir tank, control valve manifold, and solenoid valves.
- (C)** The control system located in the coach controls the system. There are 2 different control systems possible:
  - A Manual control with bubble level.
  - A Semi-automatic control, with internal leveling sensor

## **RECOMMENDED HYDRAULIC FLUIDS FOR YOUR POWER GEAR LEVELING SYSTEM**

The fluids listed here are acceptable to use in your pump assembly. Contact coach manufacturer or selling dealer for information about what specific fluid was installed in your system.

Please consult factory before using any other fluids.

In most applications,

- Type A automatic transmission fluid (ATF, Dexron III, etc.,) will work satisfactorily.
- Mercon V is also recommended as an alternative fluid for Power Gear leveling systems operating in environments with large temperature swings

Operating in cold temperatures (less than -10° F) may cause the jacks may extend and retract slowly. For cold weather operation, fluid specially-formulated for low temperatures may be desirable,

- Mobil DTE 11M, Texaco Rando HDZ-15HVI, Kendall Hyden Glacial Blu, or any Mil. Spec. H5606 hydraulic fluids are recommended for cold weather operation.

## PREVENTATIVE MAINTENANCE PROCEDURES

### **WARNING:**

**Your coach should be supported at both front and rear axles with jack stands before working underneath, failure to do so may result in personal injury or death.**

1. **Check the fluid level every month.** Fill the reservoir with the jacks in the fully **retracted** position. On 1998 - PRESENT model year coaches, the fluid should be within 1/4 inch of the fill port lip and checked only with all jacks retracted. On pre-1998 model year coaches the fluid level should be approximately 1/8 inch on the dipstick and checked only with all jacks retracted.
2. **Change fluid every 24 months.**
3. **Inspect and clean all hydraulic pump electrical connections every 12 months.**
4. **Remove dirt and road debris from jacks as needed.**
5. If jacks are down for extended periods, it is recommended to **spray exposed chrome rods with a silicone lubricant** every seven days for protection. If your coach is located in a salty environment (within 60 miles of coastal areas), it is recommended to spray the rods every 2 to 3 days.
6. Jacks equipped with grease fittings at the **bottom of the cylinder should be greased with a light weight lithium grease** using a hand pump style grease gun only. 2 or 3 pumps should be sufficient for 20-30 uses.

# REPLACEMENT JACKS (LEGS)

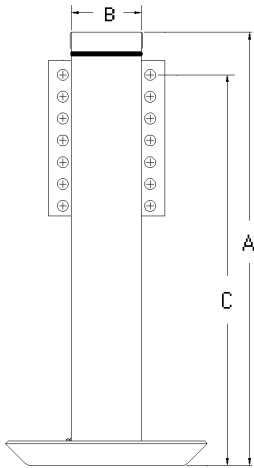

Internal Spring

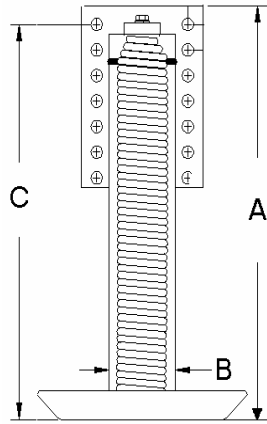

External Spring

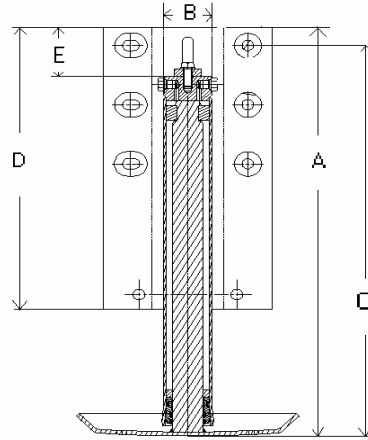

Power Level Jack

**Measurements in inches**

**Internal Spring Jacks and Rebuild Kits**

Leveling jack #	Rebuild kit #	Dimensions	
500385	kit # 800137S	A=22.25	B=3.625
500070	kit # 800131S	A=22.25	B=4.0
500145	kit # 800131S	A=22.25	B=4.0
500386	kit # 800130S	A=22.375	B=4.5
500620	kit # 800130S	A=22.375	B=4.5

500620 has a mounting pad width of 7.25

**External Spring jacks**

Jack #	Spring #	Rebuild kit #	Dimensions		
500082	500094	kit # 800129S	A=20.75	B=3.25	
500146	500094	kit # 800129S	A=20.75	B=3.25	
500272	500094	kit # 800129S	A=20.75	B=3.25	
500235	500252	kit # 800129S	A=18.25	B=3.25	C=17.38
500498	500252	kit # 800129S	A=17.75	B=3.25	C=15.0
500384	500590	kit # 800132S	A=21.25	B=2.625	(800132 kits for 2001 and later only)
500598	500590	kit # 800132S	A=21.25	B=2.625	(800132 kits for 2001 and later only)
500482	500591	kit # 800132S	A=18	B=2.625	(800132 kits for 2001 and later only)
500600	500591	kit # 800132S	A=18	B=2.625	(800132 kits for 2001 and later only)

**Power Level Jacks**

Jack #	Spring #	Rebuild kit #	Dimensions				
500730	500591	kit # 800133S	A=19.15	B=2.25	C=16	D= 8.0	
500832	500591	kit # 800133S	A=23.25	B=2.25	C=22.3	D= 8.0	
500842	500591	kit # 800133S	A=20.4	B=2.25	C=19.5	D=14.3	E=2.5
500876	500591	kit # 800133S	A=18.94	B=2.25	C=17.0	D=12.3	E= .5
500933	500591	kit # 800133S	A=19.75	B=2.25	C=17.75	D=12.3	E=1.5
500759	500094	kit # 800138S	A=20.85	B=2.6	C=17.6	D= 8	
500833	500094	kit # 800138S	A=23.15	B=2.6	C=22.2	D=14.3	E=3.0
500843	500094	kit # 800138S	A=21.15	B=2.6	C=20.2	D=14.3	E=1.0
500932	500094	kit # 800138S	A=25.3	B=2.6	C=24.4	D=14.3	E=5.0
500800	500094	kit # 800199S	A=19.2	B=3.25	C=16.75	D= 8.0	

# 1.5 GALLON CAPACITY POWER UNIT (No Longer Available)

## 1994-1998 MODEL YEARS

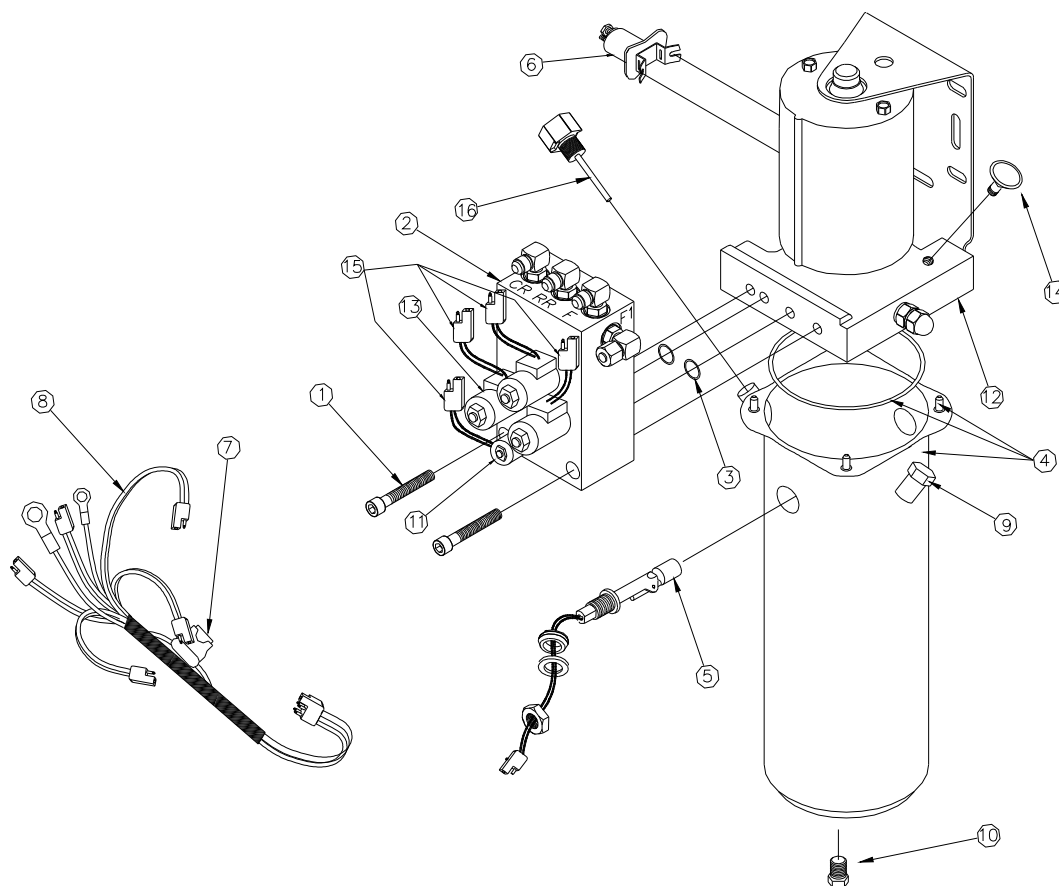

<u>ITEM</u>	<u>P/N</u>	<u>DESCRIPTION</u>	<u>QTY EACH</u>	<u>APPLICATION</u>
1-15	500465	POWER UNIT (Obsolete-Use 500507)	1	1994 - 1998
1,2,3	500334S	VALVE BLOCK ASSEMBLY (SEE PAGE 5 & 6)	1	1994 - 1998
4,9,10, 16	800038S	TANK REPLACEMENT SERVICE KIT	1	1994 - 1998
9	07-1001	FILL PLUG 3/8" NPTF	3	1998 - PRESENT
10	07-1239	DRAIN PLUG	1	1998 - PRESENT
5	500199	FLUID SENSOR ASSEMBLY	1	SEE PAGE 7
7,8	500335	PUMP HARNESS WITH FUSE	1	1994 - 1998
7	14-1055	FUSE 10 AMP	1	1994 - PRESENT
16	13-1045	DIP STICK	1	1994 - 1998
11	500097	DUMP VALVE SOLENOID	1	1994 - PRESENT
6	500310	MOTOR SOLENOID	1	1994 - PRESENT
14	06-1004	AIR BREATHER	1	1994 - PRESENT
12	13-1064	MOTOR/PUMP ASSEMBLY	1	1994 - 1998
15	500099	LEG VALVE AND SOLENOID	1	1994 - PRESENT
13	500097	DUMP VALVE AND SOLENOID	1	1994 - PRESENT

# 2.0 GALLON CAPACITY POWER UNIT ASSEMBLY

## 1999 - PRESENT

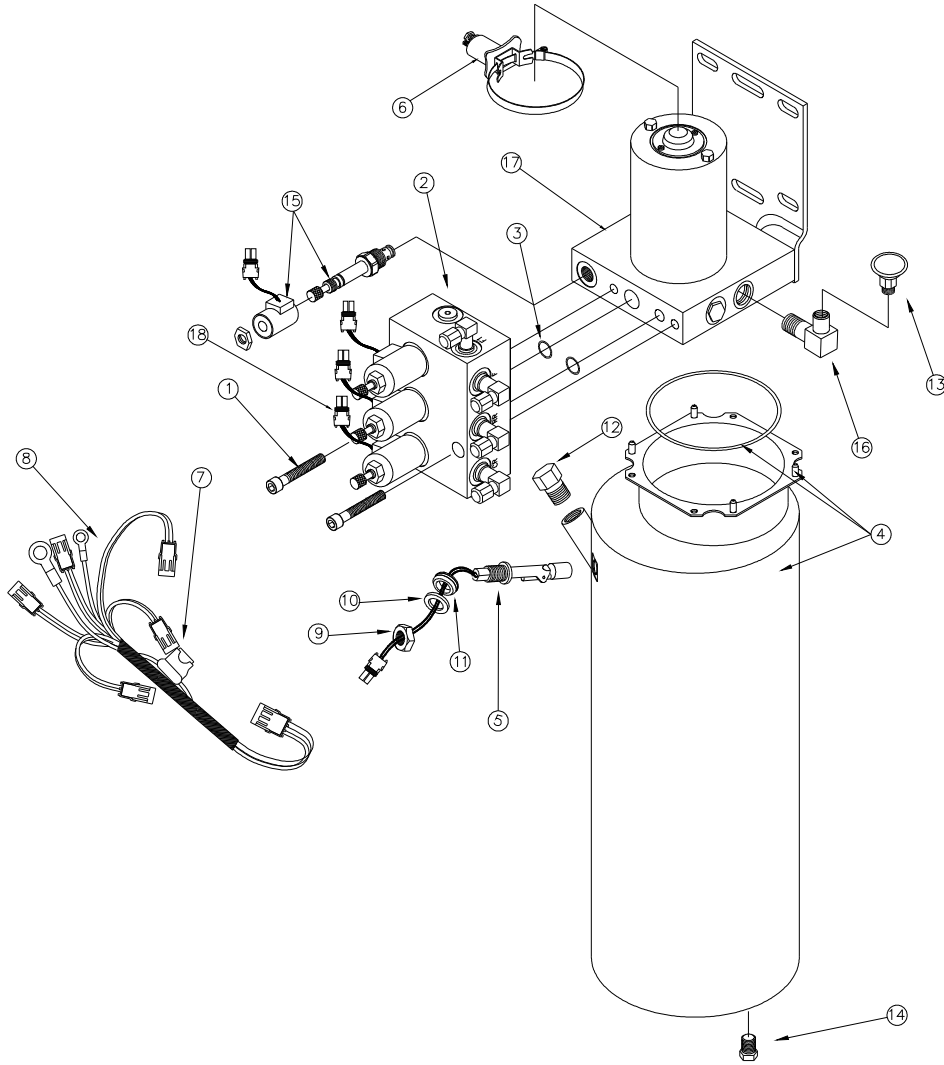

<u>ITEM</u>	<u>P/N</u>	<u>DESCRIPTION</u>	<u>QUANTITY</u>	<u>APPLICATION</u>
1-18	500507	COMPLETE POWER UNIT	1	1999 - PRESENT
1,2,3	500505	VALVE BLOCK ASSEMBLY	1	SEE PAGE 5 & 6
4,12,14	800036S	TANK REPLACEMENT SERVICE KIT	1	1999 - PRESENT
12	07-1238	FILL PLUG	1	1998 - PRESENT
14	07-1239	DRAIN PLUG	1	1998 - PRESENT
5,9,10,11	500118	FLUID SENSOR ASSEMBLY	1	1994 - PRESENT
7,8	500335	PUMP HARNESS WITH FUSE	1	1999 - PRESENT
7	14-1055	FUSE 10 AMP	1	1994 - PRESENT
15	500097	DUMP VALVE SOLENOID	1	1994 - PRESENT
6	500310	MOTOR SOLENOID	1	1994 - PRESENT
13,16	500511	AIR BREATHER, 90 DEG. ELBOW	1	1994 - PRESENT
17	13-1100	MOTOR/PUMP ASSEMBLY	1	1999 - PRESENT
18	500099	LEG VALVE AND SOLENOID	1	1994 - PRESENT

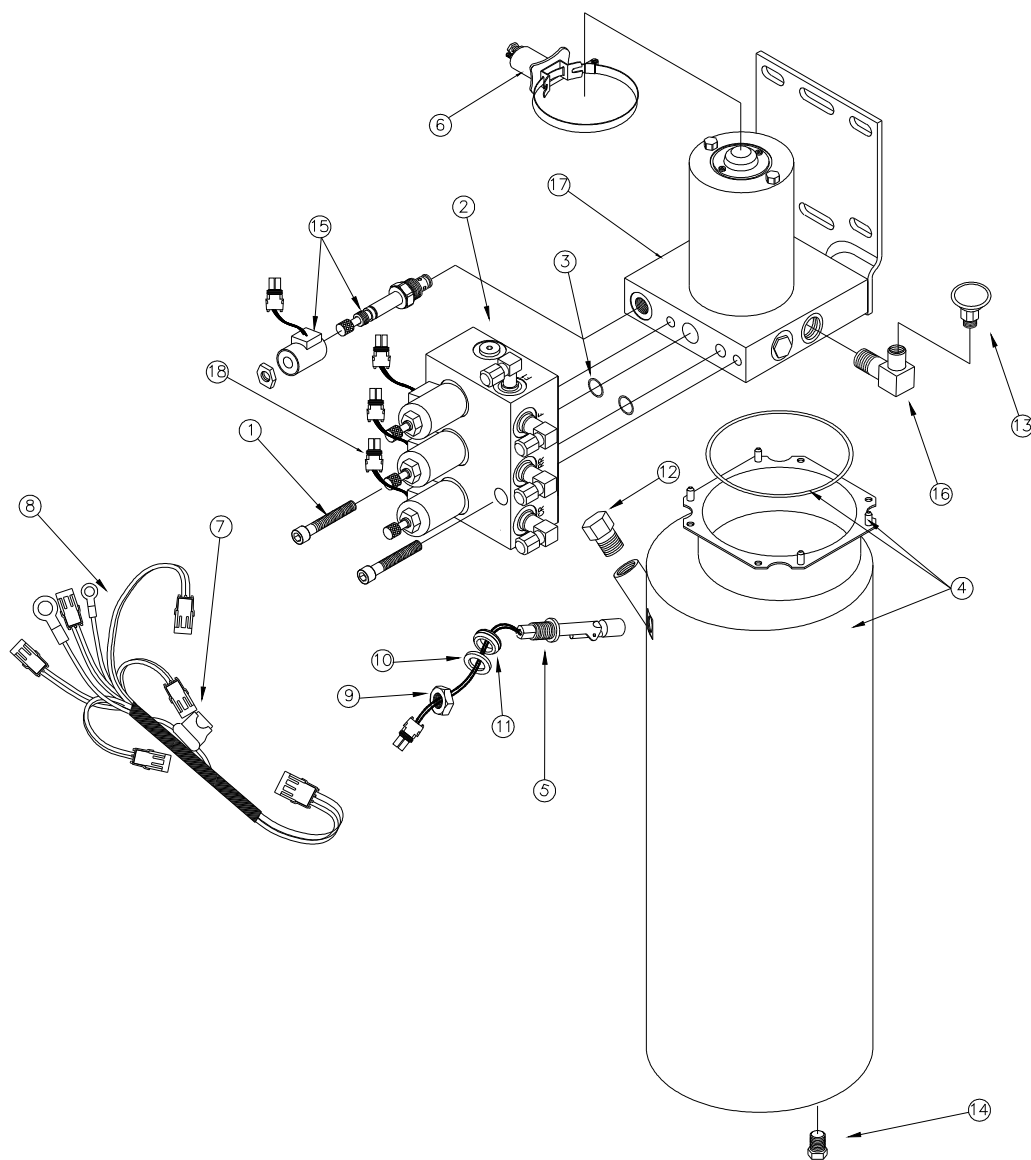

<b>ITEM</b>	<b>P/N</b>	<b>DESCRIPTION</b>	<b>QUANTITY</b>	<b>APPLICATION</b>
1-17	500453	COMPLETE POWER UNIT	1	1994 - PRESENT
1,2,3	500454	VALVE BLOCK ASSEMBLY	1	SEE PAGE 5 & 6
4,12,14	800037S	TANK REPLACEMENT SERVICE KIT	1	1994 - PRESENT
12	07-1238	FILL PLUG	1	1998 - PRESENT
14	07-1239	DRAIN PLUG	1	1998 - PRESENT
5,9,10,11	500450	FLUID SENSOR ASSEMBLY	1	SEE PAGE 7
7,8	500438	PUMP HARNESS WITH FUSE	1	1994 - 1998
7	14-1055	FUSE 10 AMP	1	1994 - PRESENT
15	500440	DUMP VALVE SOLENOID	1	SEE PAGE 5 & 6
6	500310	MOTOR SOLENOID	1	1994 - PRESENT
13,16	500511	AIR BREATHER	1	1994 - PRESENT
17	13-1104	MOTOR/PUMP ASSEMBLY	1	1994 - 1998
18	500439	LEG VALVE AND SOLENOID	1	SEE PAGE 5 & 6



## 2.5 GALLON CAPACITY POWER UNIT ASSEMBLY 1991 - 1998 MODEL YEARS (DISCONTINUED)

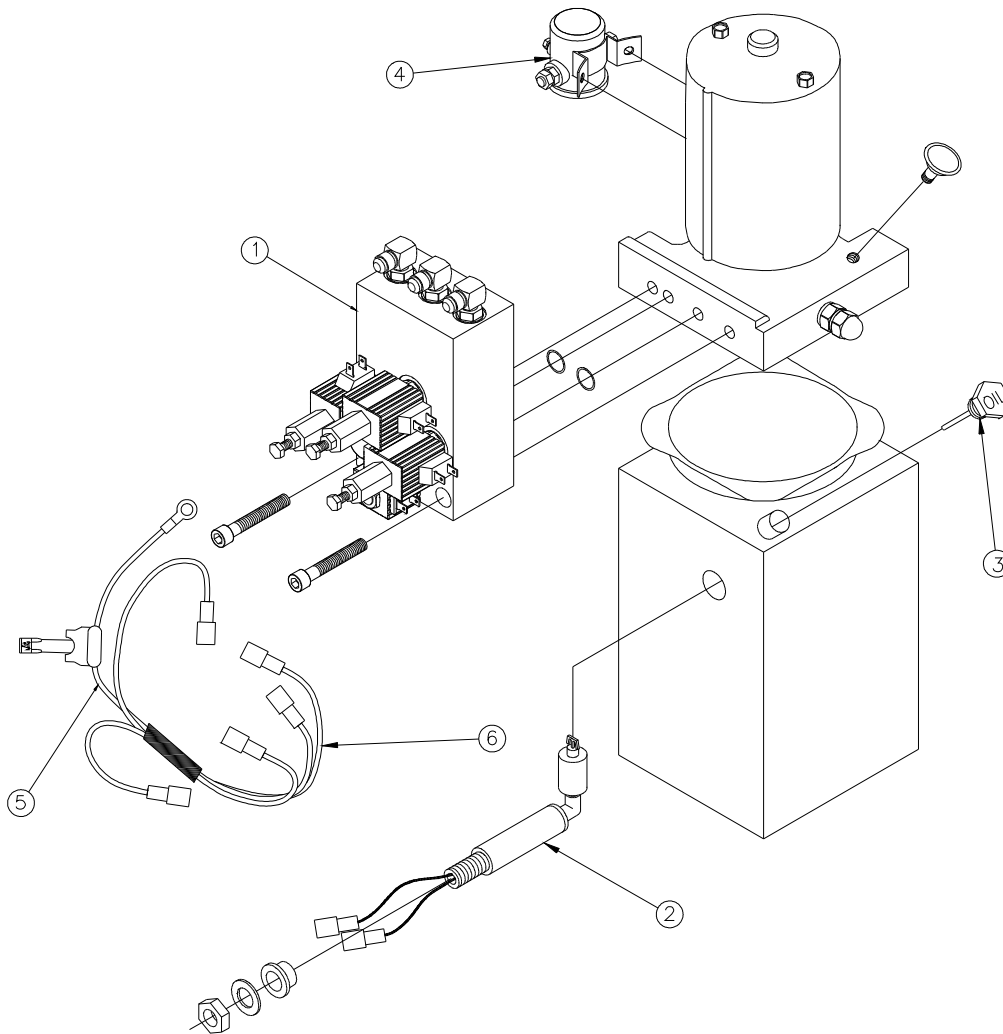

<u>ITEM</u>	<u>NOTE</u>	<u>P/N</u>	<u>DESCRIPTION</u>	<u>QUANTITY</u>	<u>APPLICATION</u>
1-6	C	500453	SQUARE TANK STYLE PUMP NO LONGER AVAILABLE ROUND TANK STYLE WILL BE SUPPLIED	1	
1	C	500524S	LARGE CAP. VALVE ASSEMBLY	1	
2	C	500119	LARGE CAP. FLUID SENSOR	1	
3		13-1045	DIP STICK	1	1994-1998
4	C	500310	12VDC SOLENOID	1	
5		14-1055	10 AMP FUSE	1	1994-PRESENT
6		500090	PUMP HARNESS	1	OBSOLETE

**C- PART CHANGED: OLD DESIGN AS SHOWN IN PICTURE NO LONGER AVAILABLE. PART NUMBER NOW CONTAINS NEW DESIGN**

## 3 OR 4 JACK (LEG) VALVE ASSEMBLY

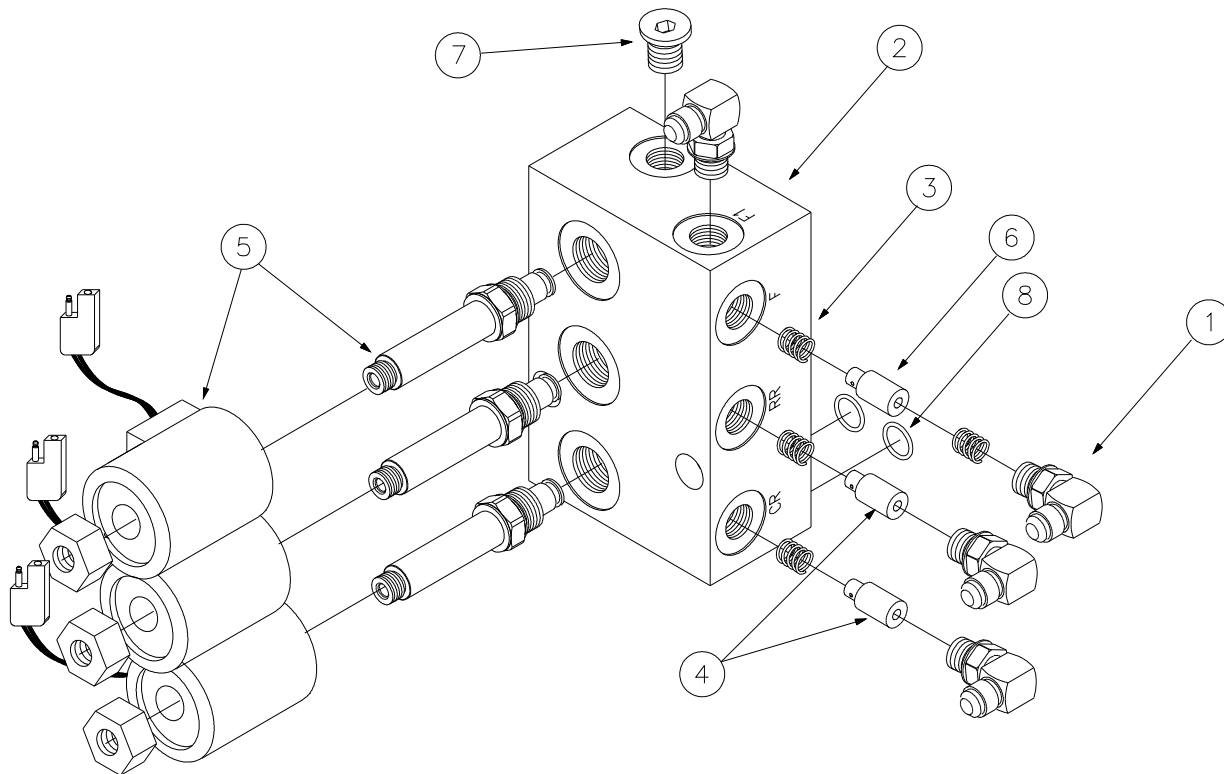

### **VALVE MANIFOLD WITHOUT MANUAL OVERRIDE**

<u>ITEM</u>	<u>P/N</u>	<u>DESCRIPTION</u>	<u>QUANTITY</u>	<u>APPLICATION</u>
1,3,4	500636S	REAR HOSE CONNECTOR KIT	1	1999 - PRESENT
1,3,6	*500637S	FRONT HOSE CONNECTOR KIT	1	1999 - PRESENT
5	500099	LEG VALVE KIT	1	1999 - PRESENT
8	500523	O-RING KIT	1	1999 - PRESENT
1-8	500338S	VALVE MANIFOLD ASSEMBLY	1	1999 - PRESENT

### **VALVE MANIFOLD WITH MANUAL OVERRIDE**

<u>ITEM</u>	<u>P/N</u>	<u>DESCRIPTION</u>	<u>QUANTITY</u>	<u>APPLICATION</u>
1,3,4	500636S	REAR HOSE CONNECTOR KIT	1	1999 - PRESENT
1,3,6	*500637S	FRONT HOSE CONNECTOR KIT	1	1999 - PRESENT
5	500439	LEG VALVE KIT	1	1999 - PRESENT
8	500523	O-RING KIT	1	1999 - PRESENT
1-8	500454S	VALVE MANIFOLD ASSEMBLY	1	1999 - PRESENT

\* = "F" PORT HAS 2 SPRINGS

# 3 OR 4 JACK (LEG) VALVE ASSEMBLY

**1994 - 1999 MODEL YEARS**

CR=CURBSIDE REAR JACK  
 RR=ROADSIDE REAR JACK  
 F=FRONT JACK - 3 JACK SYSTEM  
 F1=FRONT JACK - 4 JACK SYSTEM

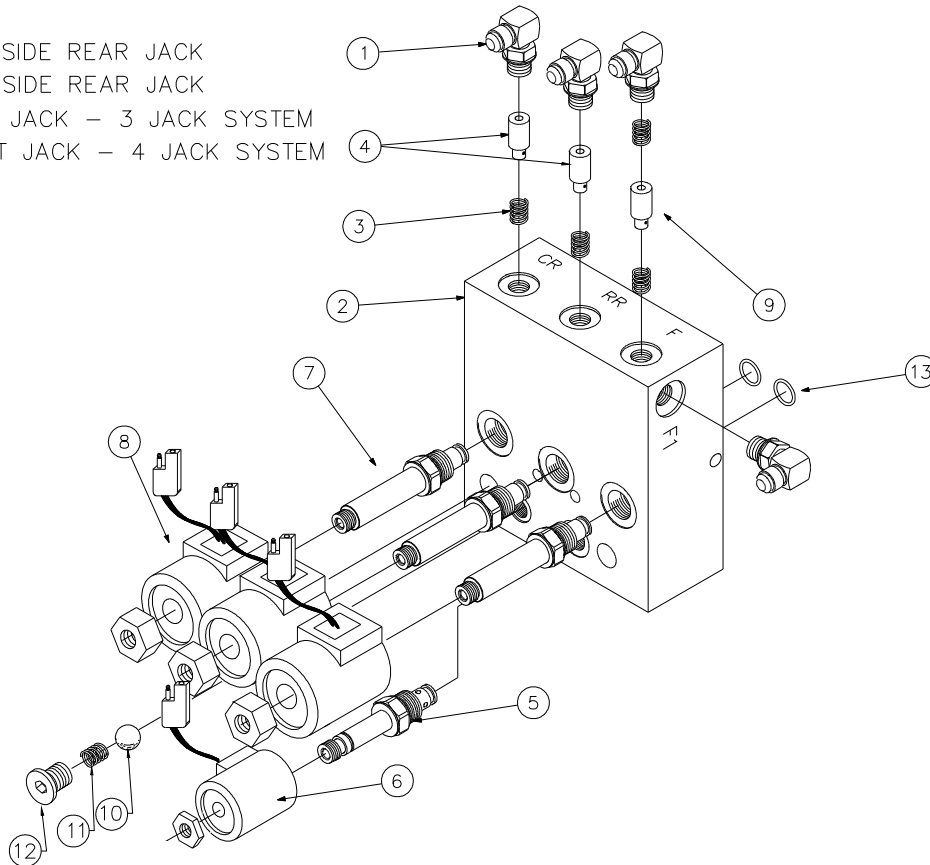

## **VALVE MANIFOLD WITHOUT MANUAL OVERRIDE**

<u>ITEM</u>	<u>P/N</u>	<u>DESCRIPTION</u>	<u>QUANTITY</u>	<u>APPLICATION</u>
1,3,4	500512	REAR HOSE CONNECTOR KIT	1	1994 - 1999
1,3,9	*500513	FRONT HOSE CONNECTOR KIT	1	1994 - 1999
10,11,12	500515	CHECK VALVE KIT	1	1994 - 1999
7,8	500099	LEG VALVE KIT	1	1994 - 1999
5,6	500097	DUMP VALVE KIT	1	1994 - 1999
13	500523	O-RING KIT	1	1994 - 1999
1-9	500334S	VALVE BLOCK ASSEMBLY	1	1994 - 1999

## **VALVE MANIFOLD WITH MANUAL OVERRIDE**

<u>ITEM</u>	<u>P/N</u>	<u>DESCRIPTION</u>	<u>QUANTITY</u>	<u>APPLICATION</u>
1,3,4	500512	REAR HOSE CONNECTOR KIT	1	1994 - 1999
1,3,9	*500513	FRONT HOSE CONNECTOR KIT	1	1994 - 1999
10,11,12	500515	CHECK VALVE KIT	1	1994 - 1999
7,8	500439	LEG VALVE KIT	1	1994 - 1999
5,6	500440	DUMP VALVE KIT	1	1994 - 1999
13	500523	O-RING KIT	1	1994 - 1999
1-9	500524S	VALVE BLOCK ASSEMBLY	1	1994 - 1999

\* = "F" PORT HAS 2 SPRINGS

## FLUID SENSORS

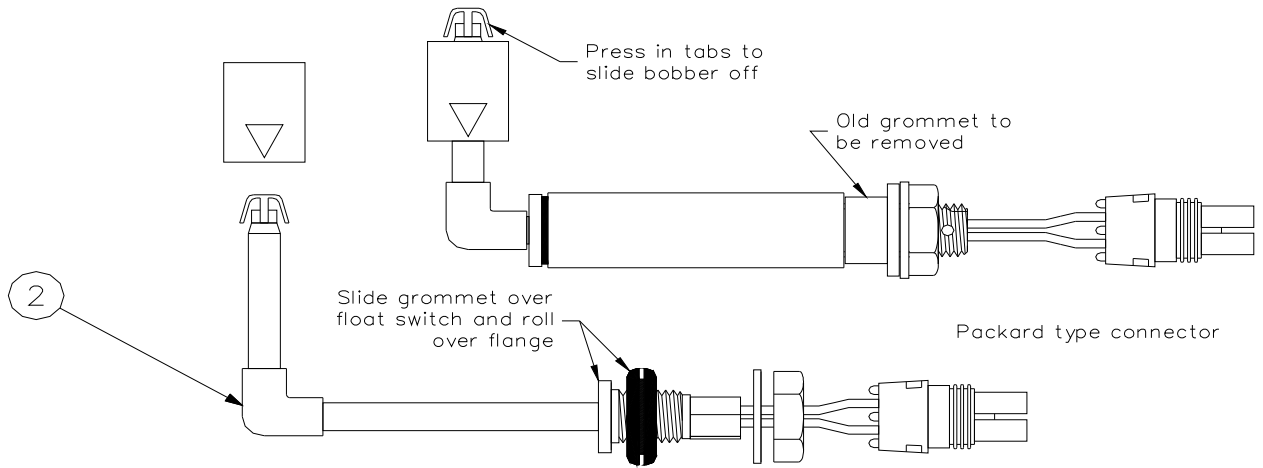
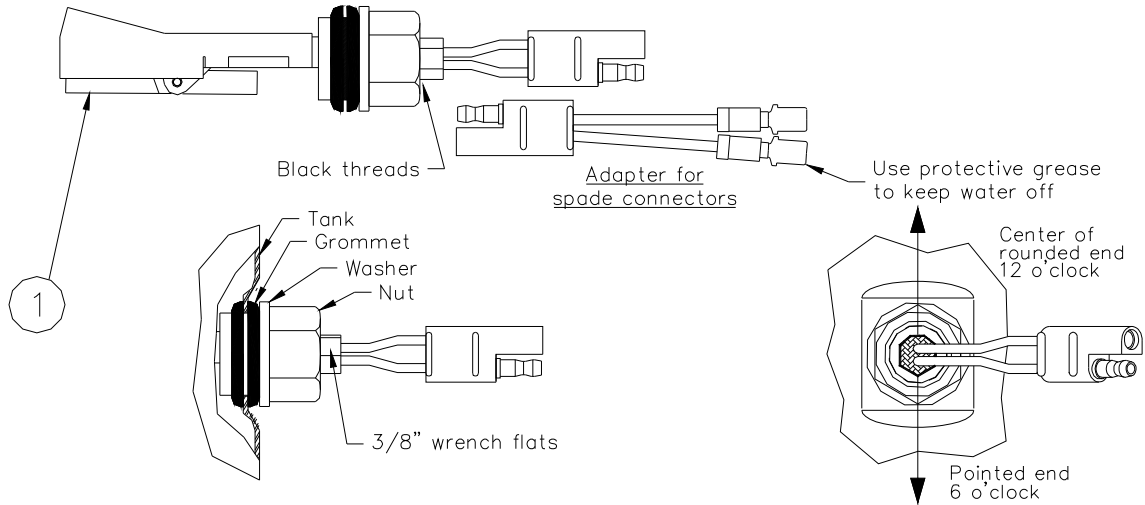

<u>ITEM</u>	<u>P/N</u>	<u>DESCRIPTION</u>	<u>QUANTITY</u>	<u>APPLICATION</u>
2	500299	FLUID SENSOR KIT (2.5 GAL. CAPACITY TANKS) (AMERICAN COACH ONLY)	1	NOV. 1995 - 1998

**THIS FLUID SENSOR IS USED ON ALL 2.5 GAL. SQUARE TANK SYSTEMS**



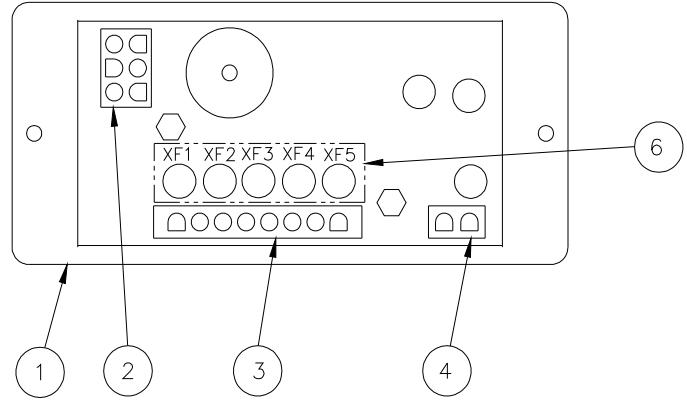
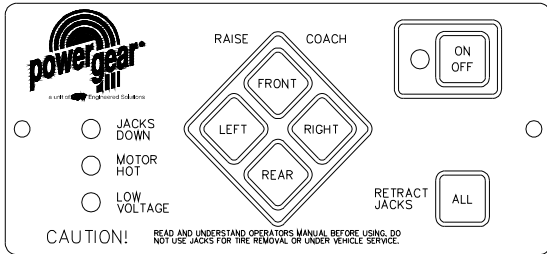

<u>ITEM</u>	<u>NOTE</u>	<u>P/N</u>	<u>DESCRIPTION</u>	<u>QUANTITY</u>	<u>APPLICATION</u>
1	C	500210	CONTROL (Obsolete-Use 500455R2)	1	SEE PAGE 10
2	N	5010-XXX	CHASSIS HARNESS	1	1994 - PRESENT
3	C	5014-XXX	COACH HARNESS	1	SEE PAGE 10
4	N	500207	JACKS DOWN LIGHT	1	1994 - 1999
5	C	800042	KIT BUBBLE LEVEL	1	
6	N	500281	FUSE KIT (5 - 1.6 AMP & 5 - 3.15 AMP)	1	1994 - 1999

**N - NOT SHOWN**

**C- PART CHANGED: OLD DESIGN AS SHOWN IN PICTURE NO LONGER AVAILABLE. PART NUMBER NOW CONTAINS NEW DESIGN**

# MANUAL TOUCH PAD CONTROL

## 1999 – PRESENT

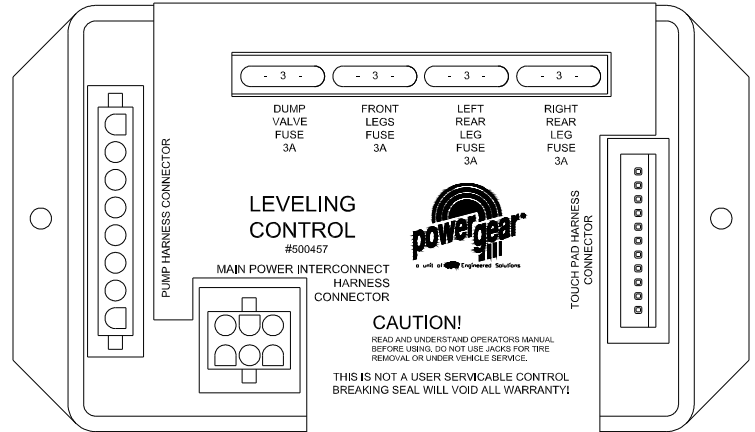
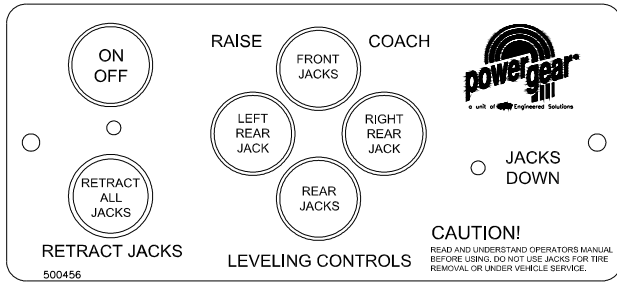

<u>ITEM</u>	<u>NOTE</u>	<u>P/N</u>	<u>DESCRIPTION</u>	<u>QUANTITY</u>	<u>APPLICATION</u>
1-3		500455R2	MANUAL CONTROL KIT	1	1999 - PRESENT
1		500456S	TOUCH PAD	1	1999 - PRESENT
2		500457S	CONTROL BOX	1	1999 - PRESENT
3	N	500491	INTERCONNECT CABLE	1	1999 - PRESENT
4	N	5010-XXX	CHASSIS HARNESS (X= length)	1	1994 - PRESENT
5	N	5014-XXX	COACH HARNESS (X indicates length)	1	1999 - PRESENT
6		800042	KIT BUBBLE LEVEL	1	1994 - PRESENT
7	N	500509	FUSE KIT (4 - 3 AMP)	1	1999 - PRESENT

**N - NOT SHOWN**

# MANUAL SYSTEM WIRING DIAGRAM

## 1994 - 1999 MODEL YEARS

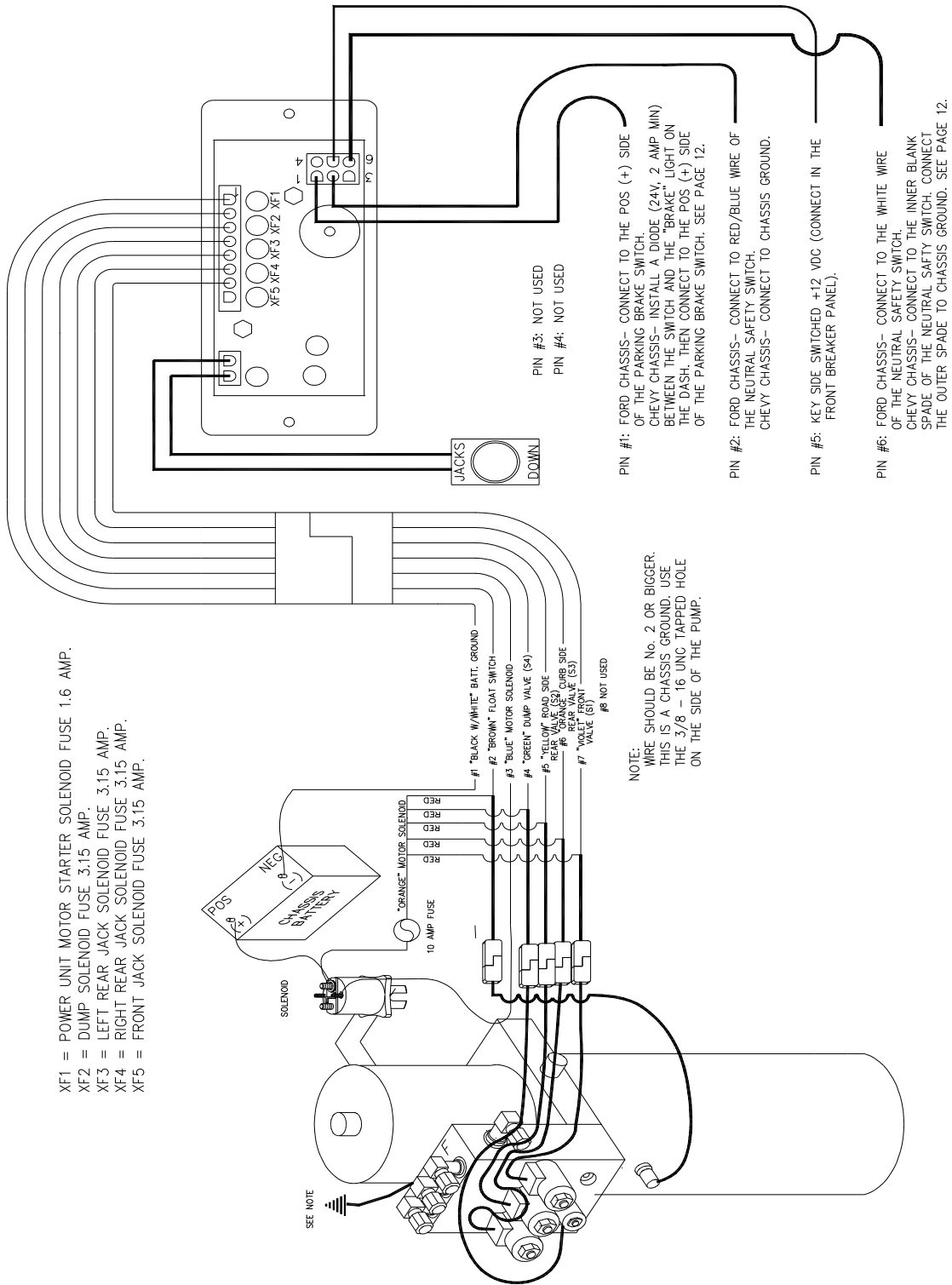



# MANUAL SYSTEM WIRING DIAGRAM

## 1999 - PRESENT

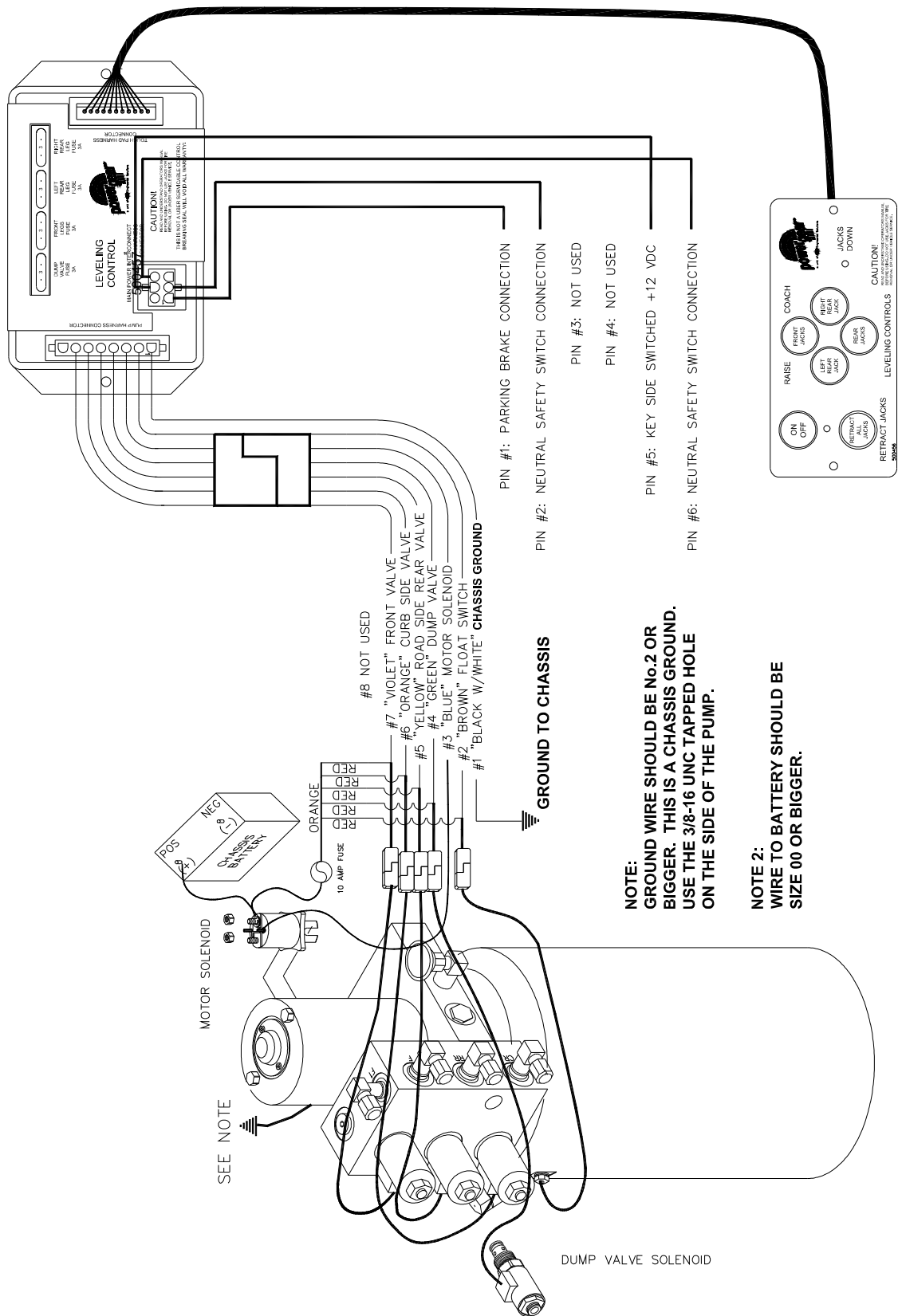

# SEMI-AUTOMATIC TOUCH PAD CONTROL

## 1991 – 1999 MODEL YEARS

1 500105

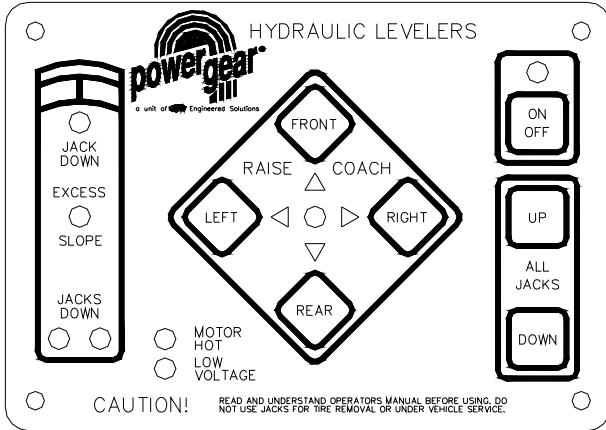

1 500105 rear view

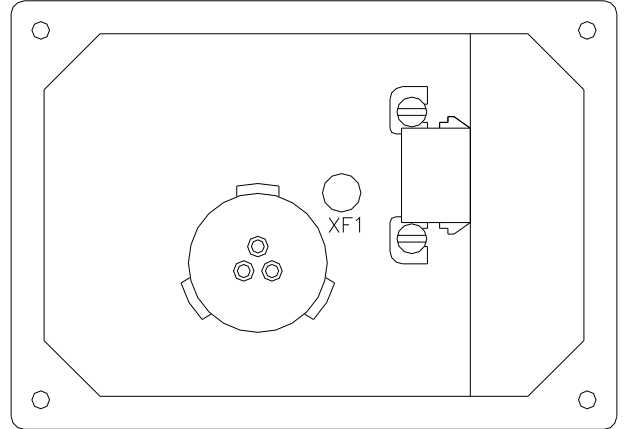

2 XF1 fuse kit

<u>ITEM</u>	<u>NOTE</u>	<u>P/N</u>	<u>DESCRIPTION</u>	<u>QUANTITY</u>	<u>APPLICATION</u>
1	C	500105	CONTROLS (Obsolete-Use 500659S) REQUIRES BOTH CONTROL PANEL AND CONTROL BOX REPLACED WITH NEW STYLE IF EITHER PART FAILS. IDENTIFY OLD CONTROL BY THE DIAMOND SHAPED BUTTONS ON CONTROL PANEL		
2	N	5003-XXX	MULTIPLEX HARNESS (X indicates length)	1	1993 - PRESENT
		500281	FUSE KIT (5 - 1.6 AMP & 5 - 3.15 AMP)	1	11/95 – PRESENT

**N - NOT SHOWN**

**C- PART CHANGED: OLD DESIGN AS SHOWN IN PICTURE NO LONGER AVAILABLE. PART NUMBER NOW CONTAINS NEW DESIGN.**

# SEMI-AUTOMATIC CONTROL BOX

1991 – 1999

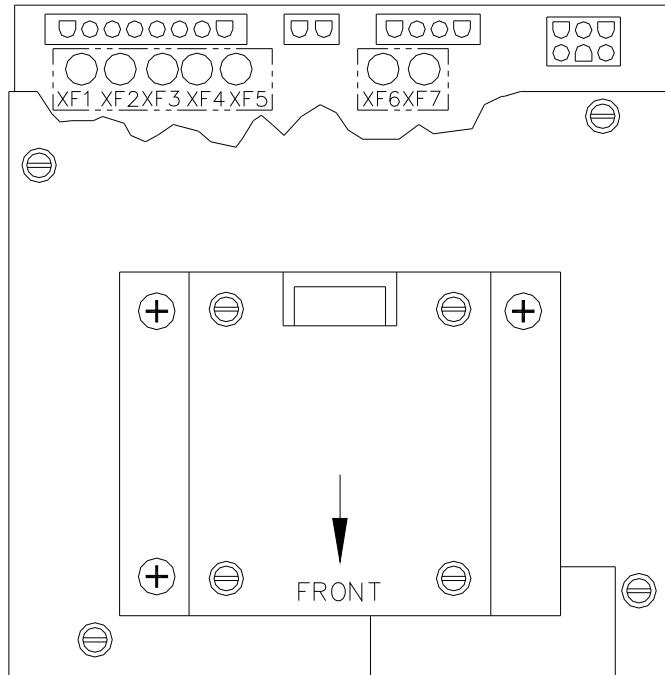

<u>ITEM</u>	<u>NOTE</u>	<u>P/N</u>	<u>DESCRIPTION</u>	<u>QUANTITY</u>	<u>APPLICATION</u>
1	C	500106	CONTROL (Obsolete-Use 500659S) REQUIRES BOTH CONTROL PANEL AND CONTROL BOX REPLACED WITH NEW STYLE IF EITHER PART FAILS. IDENTIFY OLD CONTROL BY THE DIAMOND SHAPED BUTTONS ON CONTROL PANEL		
4	N	5003-XXX	MULTIPLEX HARNESS (X indicates length)	1	1993 - 1999
2	N	5010-XXX	CHASSIS HARNESS (X indicates length)	1	1993 - 1999
2	N	5002-XXX	CHASSIS HARNESS (X indicates length) (6 PIN TRAILER CONNECTOR)	1	1993 - 1999
3	N	5014-XXX	COACH HARNESS (X indicates length) (8 PIN TRAILER CONNECTOR)	1	1993 - 1999
3	N	5001-XXX	COACH HARNESS (8 PIN TO SPADE)	1	1993 - 1998
6	N	5013-XXX	4 PIN AIR BAG DUMP HARNESS	1	1993 - 1999
5	N	500281	FUSE KIT (5 - 1.6 AMP & 5 - 3.15 AMP)	1	11/95 - 1999

**N - NOT SHOWN**

# SEMI-AUTOMATIC TOUCH PAD CONTROL

1999-Present

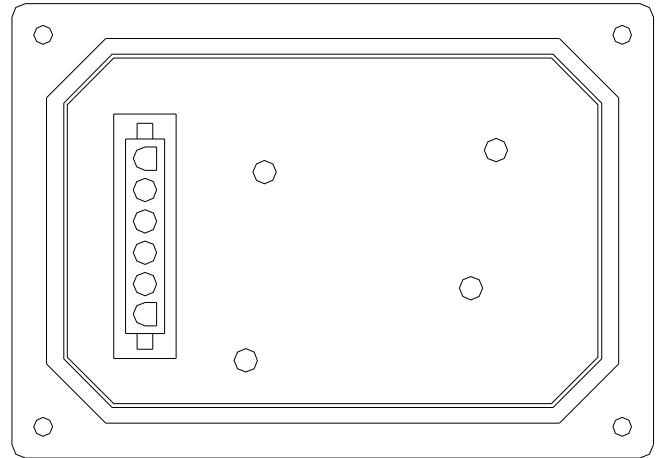
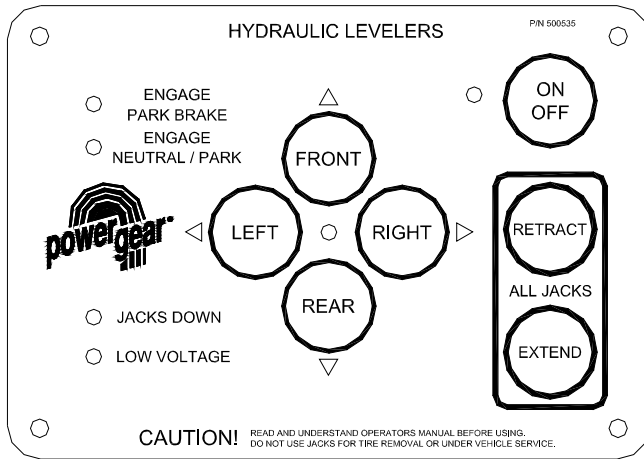

<u>ITEM</u>	<u>NOTE</u>	<u>P/N</u>	<u>DESCRIPTION</u>	<u>QUANTITY</u>	<u>APPLICATION</u>
1		500535S	SEMI-AUTOMATIC CONTROL PANEL	1	1999 – PRESENT
2	N	5017-XXX	TOUCH PAD HARNESS (X indicates length)	1	1999 – PRESENT

**N - NOT SHOWN**

# SEMI-AUTOMATIC CONTROL BOX

1999 – Present

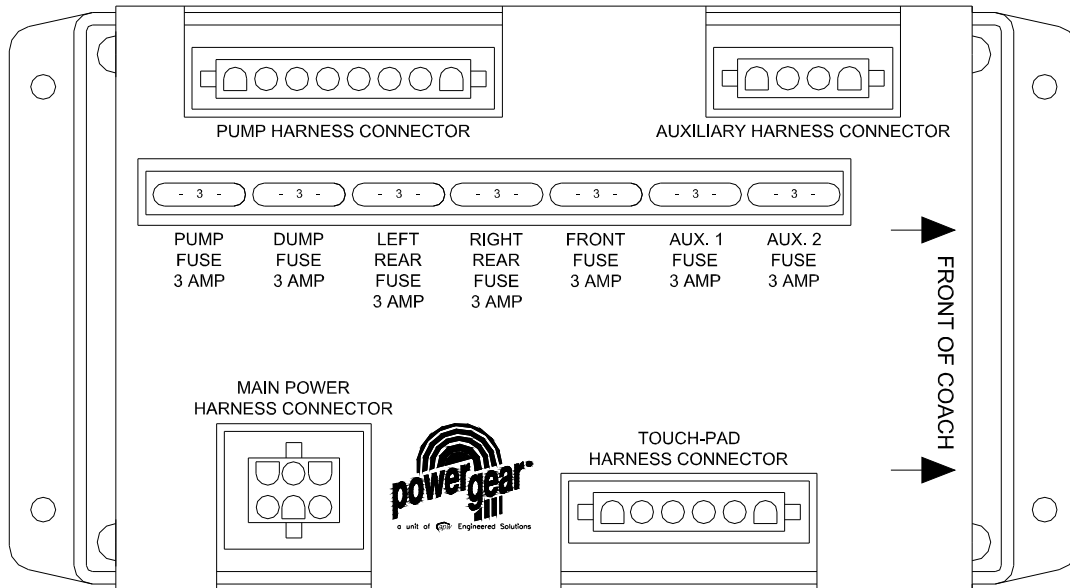

<u>ITEM</u>	<u>NOTE</u>	<u>P/N</u>	<u>DESCRIPTION</u>	<u>QUANTITY</u>	<u>APPLICATION</u>
1		500645S	SEMI-AUTOMATIC CONTROL BOX (WHITE COVER)	1	1999 – PRESENT
1		500647	SEMI-AUTOMATIC CONTROL BOX FLEETWOOD HERITAGE ONLY (YELLOW COVER)		
2	N	500663	AUXILIARY HARNESS	1	1999 – PRESENT
3	N	500509	FUSE KIT 3 AMP. (4 PC. / KIT)	1	1999 – PRESENT
4	N	5020-XXX	MAIN POWER HARNESS (X indicates length)	1	1999 – PRESENT
5	N	5017-XXX	TOUCH PAD HARNESS (X indicates length)	1	1999 – PRESENT

**N - NOT SHOWN**

# SEMI-AUTOMATIC WIRING DIAGRAM

## 1993 - 1998 MODEL YEARS

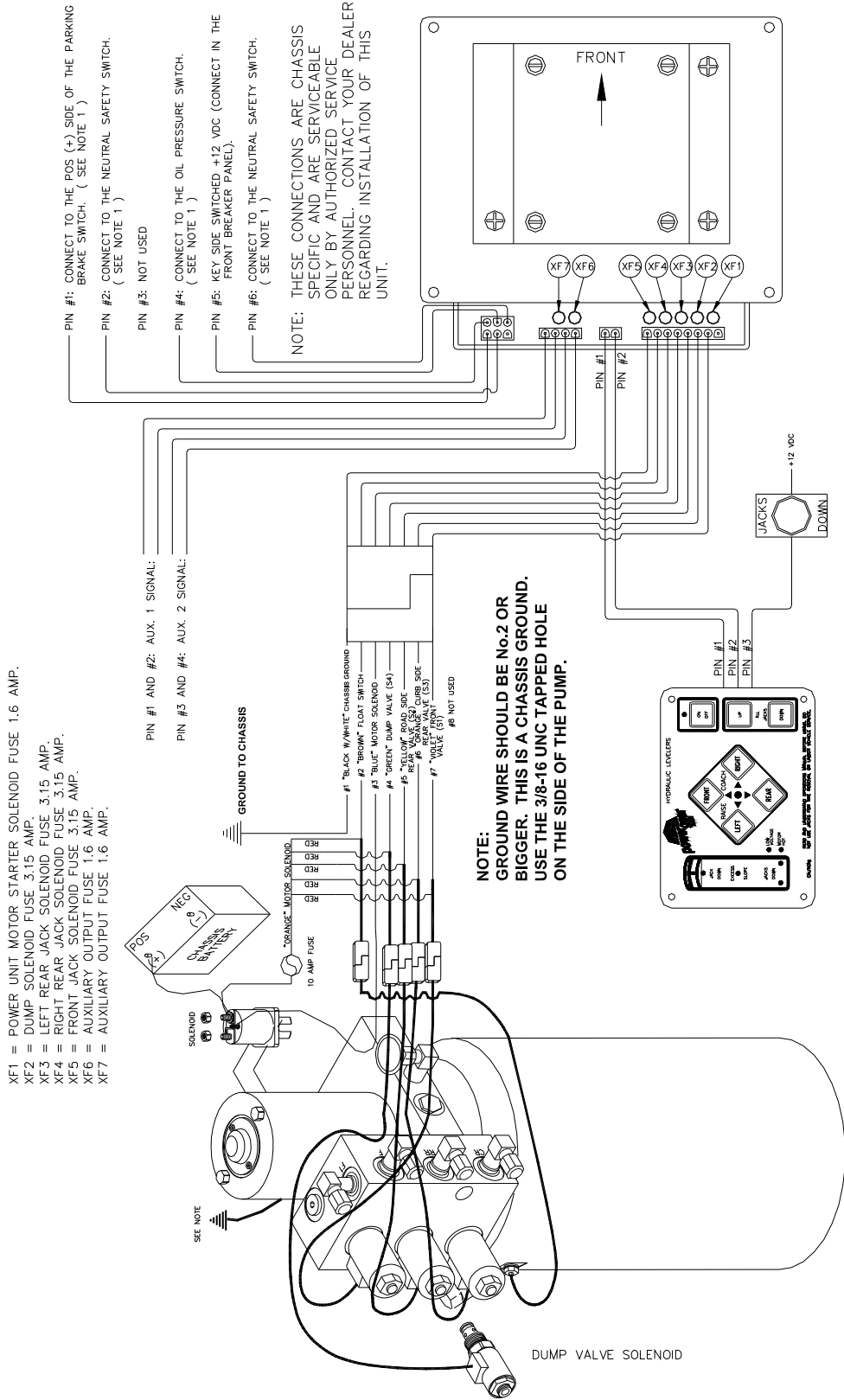



---

## SYSTEM WILL NOT TURN ON, INDICATOR LIGHT DOES NOT LIGHT

---

PROBABLE CAUSE	CORRECTIVE ACTION
COACH IGNITION NOT IN RUN POSITION	TURN IGNITION TO RUN POSITION
TRANSMISSION NOT IN PARK OR NEUTRAL	PLACE TRANSMISSION IN PARK OR NEUTRAL
PARKING BRAKE NOT SET	SET BRAKE
CONTROL HAS BEEN LEFT ON FOR MORE THAN FOUR MINUTES, AUTO SHUT OFF	PUSH ON/OFF BUTTON TWICE
NO POWER TO CONTROL	PIN #5 OF THE 6 PIN CONNECTOR ON THE CONTROL MUST HAVE +12 VDC WITH IGNITION IN RUN POSITION, CHECK COACH FUSE OR BREAKER
GROUND WIRE DISCONNECTED OR SHORTED	PIN #1 OF THE 8 PIN CONNECTOR IS THE MAIN GROUND. TEST FOR CONTINUITY WITH GROUND.
NEUTRAL SAFETY SWITCH WIRES SHORTED	JUMPER PINS #2 AND #6 AT THE 6 PIN CONNECTOR ON THE CONTROL. IF JACKS OPERATE, REPAIR OR REPLACE WIRES OR NEUTRAL SAFETY SWITCH
PARKING BRAKE WIRE NOT GROUNDED, OR FAULTY PARKING BRAKE SWITCH	CHECK CONTINUITY BETWEEN PIN #1 OF THE 6 PIN CONNECTOR AND GROUND. IF THERE IS NO CONTINUITY, THE SWITCH IS BAD, THE PARKING BRAKE IS NOT SET, OR THE WIRES TO THE SWITCH ARE BAD.
FAULTY CONTROL	IF ALL PREVIOUS CAUSES AND ACTIONS DO NOT APPLY REPLACE CONTROL

---



---

## JACKS WILL NOT EXTEND, PUMP IS NOT RUNNING

---

PROBABLE CAUSE	CORRECTIVE ACTION
(OLD CONTROL) FUSE BLOWN	REPLACE FUSE XF1 ON TOUCH PAD
MOTOR SOLENOID WIRE DEFECTIVE	CHECK FOR POWER AT THE BLUE SOLENOID SIGNAL WIRE WHILE JACKS DOWN BUTTON IS PUSHED. IF NO POWER, CHECK FUSES, WIRES, AND CONTROL..
NO POWER FROM BATTERY TO PUMP	CHECK FOR +12 VDC AT THE LARGE BATTERY TERMINAL OF THE SOLENOID, IF NO VOLTAGE RECHARGE BATTERY OR REPLACE POWER CABLE.
BAD GROUND TO PUMP MOTOR	ADD NEW GROUND CABLE FROM PUMP MOTOR TO CHASSIS BATTERY; CHECK CHASSIS GROUND CONNECTION
MOTOR SOLENOID FAULTY	CHECK FOR POWER AT THE BLUE SOLENOID SIGNAL WIRE WHILE JACKS DOWN BUTTON IS PUSHED. IF NO POWER, CHECK FUSES, WIRES, AND CONTROL. IF POWER IS PRESENT, CONNECT +12 VDC TO MOTOR SIDE TERMINAL OF SOLENOID; IF MOTOR RUNS, REPLACE SOLENOID
PUMP MOTOR FAULTY	CHECK FOR CONTINUITY BETWEEN THE MOTOR AND GROUND. CONNECT +12 VDC TO MOTOR SIDE TERMINAL OF SOLENOID; IF MOTOR DOES NOT RUN, REPLACE PUMP
FAULTY CONTROL	IF ALL PREVIOUS CAUSES AND ACTIONS DO NOT APPLY REPLACE CONTROL

---

## JACKS WILL NOT EXTEND, PUMP IS RUNNING

PROBABLE CAUSE	CORRECTIVE ACTION
FLUID LEVEL LOW; PUMP CAVITATING	FILL TANK TO PROPER LEVEL WITH AUTOMATIC TRANSMISSION FLUID SEE TIP SHEET 140
PUMP HARNESS FUSE BLOWN	CHECK FOR +12 VDC AT THE RED WIRE FOR EACH SOLENOID VALVE. IF NONE, LOCATE FUSE ON HARNESS WITHIN 18" OF PUMP IN THE CORROGATED HARNESS. REPLACE FUSE WITH 10 AMP MINI FUSE
DUMP VALVE STUCK OPEN OR FAULTY	IT MAY BE POSSIBLE TO USE A LEG VALVE TO DIAGNOSE BY SWAPPING THE DUMP VALVE AND ONE LEG VALVE. IF THE SYSTEM THEN BUILDS PRESSURE THE DUMP VALVE IS BAD (THE LEG THAT NOW HAS THE DUMP VALVE WILL MALFUNCTION). REPLACE DUMP VALVE AND RETURN LEG VALVE TO ORIGINAL POSITION.
LEG SOLENOID WIRES DAMAGED	CHECK FOR "GROUND" AT LEG COIL WIRES FROM CONTROL WHILE PUMP IS RUNNING. IF NO GROUND SIGNAL, CHECK FOR CONTINUITY ON EACH WIRE BETWEEN COIL AND CONTROLLER.
VALVE SOLENOIDS MISWIRED	CHECK WIRING DIAGRAMS
ALL CONTROL FUSES BLOWN	CHECK FOR LOW VOLTAGE TO THE CONTROLLER, SHORTS IN THE WIRING. REPLACE FUSES
FAULTY CONTROL	IF GROUND SIGNAL IS PRESENT ON BROWN WIRE (PIN #2) ON 8 PIN CONNECTOR, REPLACE CONTROL
PUMP FAILURE	IF ALL PREVIOUS CAUSES AND ACTIONS DO NOT APPLY REPLACE PUMP/MOTOR ASSY.

## ONLY FRONT JACKS WILL NOT EXTEND, PUMP IS RUNNING

PROBABLE CAUSE	CORRECTIVE ACTION
FUSE BLOWN	OLD CONTROL: REPLACE FUSE XF5 ON TOUCH PAD : NEW CONTROL REPLACE "FRONT LEG " FUSE
FRONT JACK COIL GROUND WIRE FAULTY	PIN #7 OF THE 8 PIN CONNECTOR COMPLETES CIRCUIT (SWITCHES TO GROUND WITH BUTTON PUSHED) CHECK FOR CONTINUITY, IF NONE REPLACE WIRE
FRONT JACK COIL +12 VDC WIRE FAULTY	CHECK FOR +12 VDC AT THE COIL TERMINAL, OF NOT REPLACE WIRE.
FRONT JACK VALVE SOLENOID DEFECTIVE	CHECK COIL FOR CONTINUITY, IF NONE REPLACE SOLENOID
FRONT JACK VALVE FAULTY	REPLACE SOLENOID VALVE

**ANY ONE OF THE REAR JACKS WILL NOT EXTEND,  
PUMP IS RUNNING**

<b>PROBABLE CAUSE</b>	<b>CORRECTIVE ACTION</b>
FUSE BLOWN	OLD CONTROL: REPLACE FUSE XF3 ON TOUCH PAD FOR ROAD SIDE JACK REPLACE FUSE XF4 FOR CURB SIDE JACK
	NEW CONTROL: REPLACE 'LEFT REAR JACK' OR 'RIGHT REAR JACK' FUSE ON CONTROL BOX
JACK COIL +12 VDC WIRE FAULTY	CHECK FOR 12 VDC ON RED COIL WIRE. IF NONE CHECK FUSE AND WIRE.
VALVE SOLENOID COIL IS DEFECTIVE	CHECK COIL FOR CONTINUITY, IF NONE REPLACE SOLENOID
OPEN IN WIRE HARNESS	CHECK FOR 12 VDC AT PIN 5 OR 6 OF THE EIGHT PIN CONNECTOR. IF NO 12VDC, REPLACE WIRE.
JACK VALVE FAULTY	REPLACE SOLENOID VALVE

**ALL JACKS WILL NOT RETRACT OR WILL NOT RETRACT FULLY**

<b>PROBABLE CAUSE</b>	<b>CORRECTIVE ACTION</b>
DUMP VALVE FUSE BLOWN	OLD CONTROL: REPLACE FUSE XF2 ON TOUCH PAD
	NEW CONTROL: REPLACE 'DUMP VALVE' FUSE ON CONTROL BOX
SYSTEM OVERFILLED WITH FLUID	DRAIN FLUID TO RECOMMENDED LEVEL-SEE TIP 140
PUMP HARNESS FUSE BLOWN	LOCATE FUSE ON HARNESS WITHIN 18" OF PUMP IN THE CORROGATED HARNESS. REPLACE FUSE WITH 10 AMP MINI FUSE
SYSTEM IS OPERATING AS IF THE JACKS ARE ALREADY RETRACTED	CHECK FLOAT SWITCH OPERATION. CHECK THE FLOAT SWITCH FOR PROPER ORIENTATION. CHECK THE SYSTEM FOR OVERFILLING. CHECK FOR CONTINUITY ON BROWN WIRE FROM FLAOT SWITCH TO CONTROL. CHECK FOR 12 VDC TO FLOAT ON RED WIRE.
DUMP SOLENOID COIL GROUND WIRE FAULTY	PIN #4 OF THE 8 PIN CONNECTOR COMPLETES CIRCUIT CHECK FOR CONTINUITY, IF NONE REPLACE WIRE (SWITCHES TO GROUND WITH BUTTON PUSHED)
DUMP SOLENOID COIL +12 VDC WIRE FAULTY	CHECK FOR +12 VDC AT THE COIL TERMINAL. IF NONE CHECK FUSE AND WIRE
DUMP SOLENOID COIL DEFECTIVE	CHECK COIL FOR CONTINUITY, IF NONE REPLACE SOLENOID
DUMP SOLENOID VALVE FAULTY	REPLACE VALVE
FAULTY CONTROL	IF ALL PREVIOUS CAUSES AND ACTIONS DO NOT APPLY REPLACE CONTROL SEE TIP SHEETS 39, 65

## ANY ONE OR TWO JACKS WILL NOT RETRACT AT ALL

PROBABLE CAUSE	CORRECTIVE ACTION
BROKEN JACK SPRING (S)	REPLACE JACK SPRING SEE TIP SHEET 34
FUSE ON CONTROL PANEL BLOWN	OLD CONTROL: REPLACE FUSE XF3 FOR ROAD SIDE JACK REPLACE FUSE XF4 FOR CURB SIDE JACK REPLACE FUSE XF5 FOR FRONT JACK (S) ON TOUCH PAD NEW CONTROL: REPLACE 'FRONT LEGS', 'LEFT REAR LEG' OR 'RIGHT REAR JACK' FUSE ON CONTROL BOX
JACK COIL GROUND WIRE FAULTY	PIN #5 OF THE 8 PIN CONNECTOR COMPLETES CIRCUIT FOR ROAD SIDE JACK PIN #6 OF THE 8 PIN CONNECTOR COMPLETES CIRCUIT FOR CURB SIDE JACK PIN #7 OF THE 8 PIN CONNECTOR COMPLETES CIRCUIT FOR FRONT JACK (S) CHECK FOR CONTINUITY, IF NONE REPLACE WIRE
JACK COIL +12 VDC WIRE FAULTY	CHECK FOR +12 VDC AT THE COIL TERMINAL IF NONE CHECK FUSE AND WIRE CHECK COIL FOR CONTINUITY, IF NONE REPLACE SOLENOID
JACK ROD GUIDE IS RUSTED OR DIRTY	CLEAN CHROME ROD, GREASE ROD GUIDE IF EQUIPPED WITH GREASE FITTINGS. OTHERWISE LUBRICATE WITH SILICONE FLUID. IT MAY BE NECESSARY TO RESEAL JACK OR REPLACE.
JACK VALVE FAULTY	REPLACE SOLENOID VALVE
JACK VALVE COIL IS DEFECTIVE	CHECK COIL FOR CONTINUITY. IF NONE, REPLACE COIL.

## ANY JACK RETRACTS VERY SLOWLY

PROBABLE CAUSE	CORRECTIVE ACTION
SHUNT VALVE CLOGGED	REMOVE HOSE FITTING ON MANIFOLD FOR THAT JACK, TO GAIN ACCESS TO VALVE. CLEAN VALVE PASSAGES WITH SOLVENT AND COMPRESSED AIR.
SHUNT VALVE SPRING DAMAGED	REPLACE SPRING
HOSE DAMAGED	REPLACE KINKED, OR DAMAGED HOSE (DAMAGE MAY NOT BE VISIBLE EXTERNALLY)
JACK ROD GUIDE IS RUSTED OR DIRTY	CLEAN CHROME ROD, GREASE ROD GUIDE IF EQUIPPED WITH GREASE FITTINGS. OTHERWISE LUBRICATE WITH SILICONE FLUID. IT MAY BE NECESSARY TO RESEAL JACK OR REPLACE.
INTERNAL FAILURE WITHIN JACK	REBUILD / REPLACE COMPONENTS OR JACK AS NECESSARY.

**ANY JACK RETRACTS WITH NO POWER,  
WITH POSSIBLE POPPING SOUND**

<b>PROBABLE CAUSE</b>	<b>CORRECTIVE ACTION</b>
AIR IN SYSTEM	CHECK FOR COILS IN HOSE. REMOVE THE COIL IF PRESENT THEN EXTEND ALL JACKS TO FULL EXTENSION, THEN RETRACT FULLY, REPEAT 4 CYCLES WAITING A FEW MINUTES BETWEEN CYCLES, CHECK FLUID LEVEL IN BETWEEN CYCLES
CONTAMINATED FLUID	REPLACE FLUID, SEE PAGE A3, TIP SHEET 140 AND 141.
LEG SOLENOID VALVES STUCK OPEN	REMOVE SOLENOID VALVE, CLEAN OR REPLACE
DUMP SOLENOID VALVE CONTAMINATED	REMOVE SOLENOID VALVE, CLEAN OR REPLACE
DUMP SOLENOID VALVE STUCK OPEN	REPLACE SOLENOID VALVE
ALL SOLENOID VALVES STUCK OPEN	REPLACE ALL VALVES
JACK LEGS CREATE POPPING SOUND	EXTEND JACK LEGS, CLEAN ROD, LUBRICATE WITH LIGHT WEIGHT GREASE IF EQUIPPED WITH GREASE FITTINGS OR LUBRICATE WITH SILICONE SPRAY
	DUE TO CHANGES IN TEMPERATURE, EXPANDING AND CONTRACTING OF FLUID WILL MAGNIFY THE PROBLEM OF POPPING JACKS, TO HELP MINIMIZE THIS REPLACE FLUID WITH MERCON V FLUID

**PANEL JACKS DOWN LIGHT WILL NOT GO ON  
WITH JACKS EXTENDED**

<b>PROBABLE CAUSE</b>	<b>CORRECTIVE ACTION</b>
HARNESS WIRE FAULTY	CHECK FOR +12 VDC AT FLUID SENSOR
	REPLACE 10 AMP MINI FUSE ON PUMP HARNESS
FLUID SENSOR MIS ADJUSTED	SEE TIP SHEET 30, 54 OR 81 FOR FLUID SENSOR ORIENTATION
FLUID SENSOR FAULTY	CHECK FLUID SENSOR FOR CONTINUITY* WITH JACKS EXTENDED, IF NO CONTINUITY, REPLACE SENSOR * CONTINUITY: PRE 2001 MODELS, RESISTANCE SHOULD BE NEAR ZERO. FOR 2001 AND NEWER UNITS, RESISTANCE SHOULD BE NEAR 1 KW
OPEN ON THE BROWN WIRE	CHECK FOR CONTINUITY BETWEEN BROWN WIRE AT FLOAT SENSOR AND BROWN WIRE AT CONTROL. IF NONE REPLACE WIRE.
DEFECTIVE LIGHT ON TOUCH PAD	APPLY +12 VDC AT BROWN WIRE TO 8 PIN HARNESS WITH KEY ON. IF NO LIGHT. REPLACE TOUCH PAD, CONTROL, OR BOTH.

---

**PANEL JACKS DOWN LIGHT WILL NOT GO OFF  
WITH JACKS RETRACTED**

---

<b>PROBABLE CAUSE</b>	<b>CORRECTIVE ACTION</b>
LOW FLUID LEVEL	FILL TANK WITH AUTOMATIC TRANSMISSION FLUID SEE PAGE A3 AND TIP SHEET 140
FLUID SENSOR MISADJUSTED	SEE TIP SHEET 30, 54 OR 81 FOR FLUID SENSOR ORIENTATATION
FLUID SENSOR FAULTY	CHECK FLUID SENSOR FOR CONTINUITY* WITH JACKS EXTENDED, IF NO CONTINUITY, REPLACE SENSOR * : PRE 2001 MODELS, RESISTANCE SHOULD BE NEAR ZERO. FOR 2001 AND NEWER UNITS, RESISTANCE SHOULD BE NEAR 1 KW

---

**PANEL JACKS DOWN LIGHT AND ALARM WILL GO ON WHILE  
DRIVING, JACKS RETRACTED**

---

<b>PROBABLE CAUSE</b>	<b>CORRECTIVE ACTION</b>
LOW FLUID LEVEL	FILL TANK WITH AUTOMATIC TRANSMISSION FLUID SEE TIP SHEET 140
FLUID SENSOR MISADJUSTED	SEE TIP SHEET 30, 54 OR 81 FOR FLUID SENSOR ORIENTATION
FLOAT SENSOR FAULTY	CHECK FLUID SENSOR FOR CONTINUITY* WITH JACKS EXTENDED, IF NO CONTINUITY*, REPLACE SENSOR: PRE 2001 MODELS, RESISTANCE SHOULD BE NEAR ZERO. FOR 2001 AND NEWER UNITS, RESISTANCE SHOULD BE NEAR 1 KW
SHORT IN HARNESS	CHECK PUMP HARNESS FOR CROSSED CIRCUITS, CONTACT FACTORY FOR FURTHER INFORMATION.

---